

## Quick Start Guide



## Compact Excavators

18z-1, 19c-1, 19c-1 EP



## Disclaimer

- > This Quick Reference Guide is to provide quick and simple information to the Operator and does not include any health and safety aspects. In addition, because of our continual development of machines, features described in this Quick Reference Guide may differ from those on your machine. No errors and emissions be entirely ruled out.
- > This Quick Reference Guide **DOES NOT** replace the Operators Manual. You **MUST** read **ALL** the disclaimers and safety and other instructions in the Operators Manual before initially operating this product. Accordingly, no legal claims can be entertained on the basis of the data, illustrations or descriptions in this Quick Reference Guide.
- > This machine should not be operated by any person who isn't appropriately qualified or had the appropriate training.
- > Operation of this machine without periodic maintenance could cause it to malfunction. For more information please contact your JCB Dealer.

## Index

Intended Use.....	4
Dimensions .....	5
Tie Down Points .....	6-7
Lifting Points .....	8
Cab Layout & Controls.....	9-14
Start Up Sequence .....	15
Hydraulic Hitch Unlock.....	16
Mechanical Hitch Unlock .....	17
Shutdown & Auxiliary Venting.....	18
Maintenance Position .....	19
Service / Maintenance.....	20
Access Covers .....	21-22
Fluids & Lubricants.....	23
Machine Attachments .....	24
Troubleshooting / FAQs.....	25-26
Your Notes.....	27

## Intended Use

### General

- > Machine Type – Compact Excavator
- > Self propelled machine with a tracked undercarriage
- > 360° revolving upper structure with boom, dipper, bucket and slew mechanism

### Intended Use

- > Machine intended to be used in normal conditions as detailed in the operators manual
- > With bucket fitted, machine work cycle consists of digging, elevating, slewing and discharging of materials
- > Applications include earthmoving, road construction, building and construction, landscaping etc.
- > Can be used for object handling if fitted with relevant parts and systems
- > Not intended for use in mining and quarrying applications, demolition, forestry, any use underground and any explosive atmospheres
- > Must not be used for forestry, used with attachments of unknown weight, used on surfaces with unknown stability – list not exhaustive
- > PPE may be required in certain applications/environments e.g. high silica concentration or asbestos
- > The machine should not be operated by any person without appropriate qualifications, training or experience of using this type of machine
- > Prior to use, the machines suitability should be considered with regards to the intended applications and any hazards which may be present

## Dimensions

Fig 1

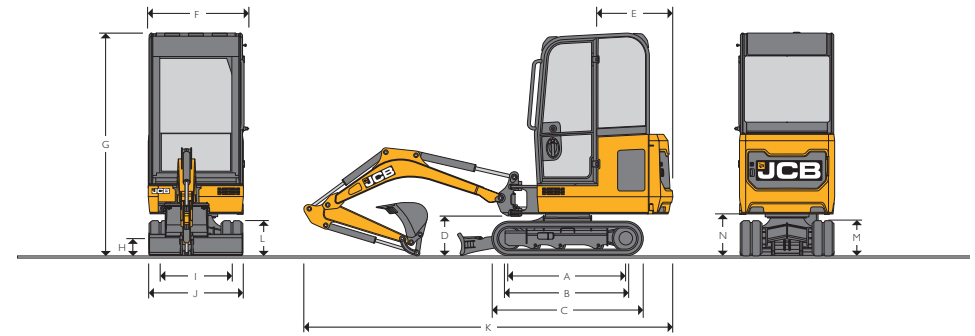

Machine model		18z-1	19c-1	19c-1 EP	
A	Sprocket idler centres	mm	1218		
B	Track length on ground	mm	1220		
C	Undercarriage overall length – rubber	mm	1578		
	Undercarriage overall length – steel	mm	1578		
D	Kingpost clearance	mm	409		
E	Tailswing radius	mm	685	1103	1103
F	Overall width of superstructure	mm	996	996	996
G	Height over cab	mm	2324		
	Height over canopy	mm	2340	2324	2324
H	Ground clearance	mm	162		
I	Track gauge – Retracted	mm	750		
	Track gauge – Extended	mm	1110		
J	Width over tracks – Retracted	mm	980		
	Width over tracks – Extended	mm	1330		
K	Transport length with standard dipper	mm	3547	3860	3862
L	Track height	mm	367		
M	Counterweight clearance	mm	434		
N	Operating mass*	kg	1749	1910**	1943**

\* Standard machine specification, please see data plate for specific machine weight.

\*\* Cab variant.

## Tie Down Points

When transporting the machine one of the following three methods should be used:

### Method 1

Fig 2

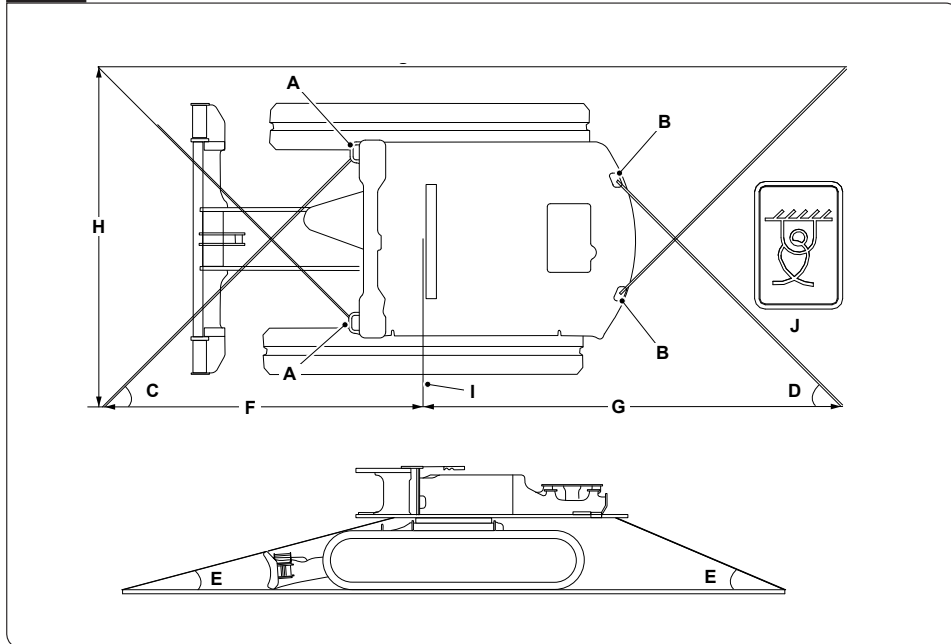

- A** Front slew spine tie-down point
- B** Rear slew spine tie-down point
- C** Angle = 35° to 46°
- D** Angle = 45° to 50°
- E** Angle = 9° to 15°
- F** Length = 2,499mm to 1,846mm
- G** Length = 2,720mm to 1,943mm
- H** Length = 2,500mm
- I** Slew ring centre line
- J** Tie down decal

Tie Down Position Decal



REFER TO OPERATORS MANUAL TRANSPORTING MACHINE

## Tie Down Points

### Method 2

Fig 3

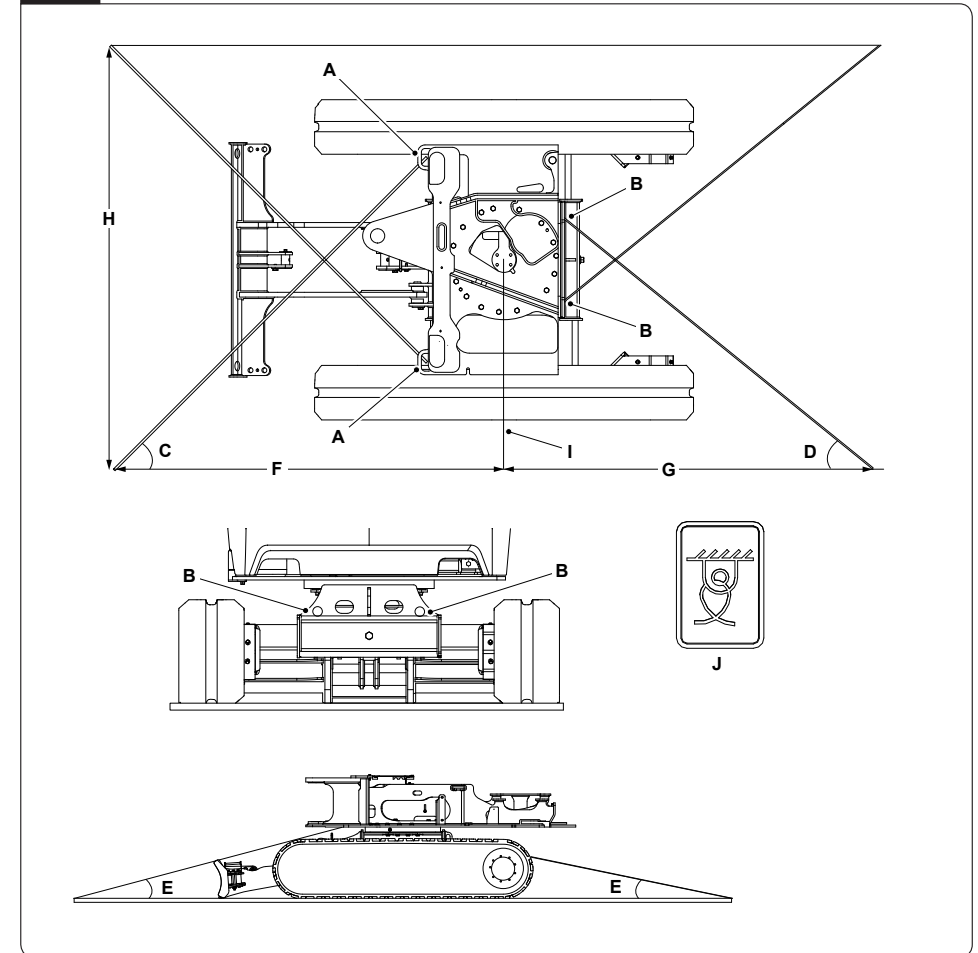

- A** Front slew spine tie-down point
- B** Rear slew spine tie-down point
- C** Angle = 35° to 46°
- D** Angle = 35° to 45°
- E** Angle = 9° to 15°
- F** Length = 2,499mm to 1,846mm
- G** Length = 2,282mm to 1,670mm
- H** Length = 2,500mm
- I** Slew ring centre line
- J** Tie down decal

REFER TO OPERATORS MANUAL TRANSPORTING MACHINE

## Lifting Points

Fig 4

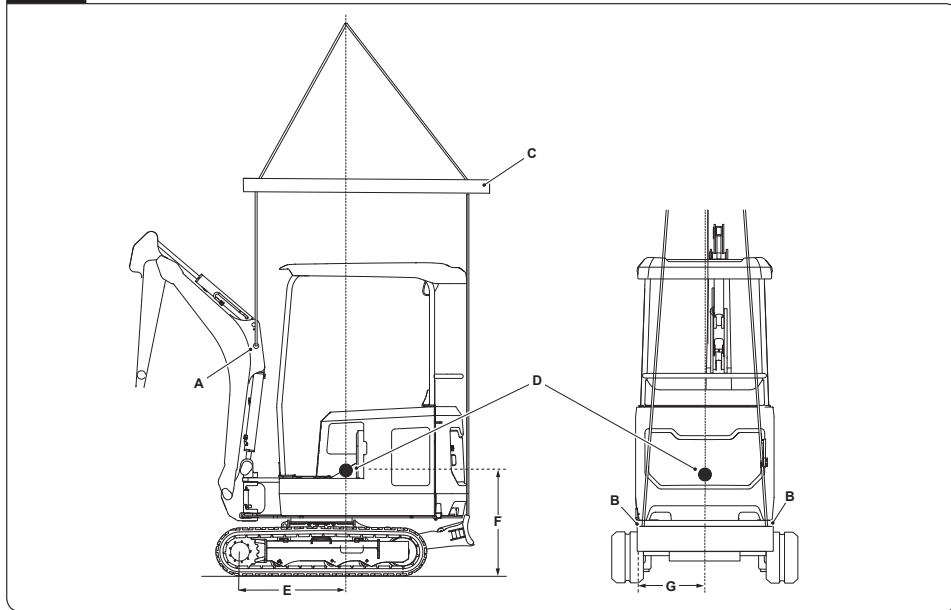

Description		18z-1	19c-1	19c-1 EP
A		Boom Lift Point		
B		Dozer Blade Lift Point		
C		Spreader Bar		
D		Centre of Gravity		
E	mm	632	792	792
F	mm	659	639	639
G	mm	525	533	533

\*COG = Centre of Gravity

The correct lifting positions are identified on the machine by their labels:

Fig 5



Lifting point  
Position label.

REFER TO OPERATORS MANUAL TRANSPORTING MACHINE

## Cab & Switch Panel

### Operator Station Layout – 18z-1, 19c-1

Fig 6

- A Auxiliary pedal
- B Track Controls
- C Swing left/ right
- D Heater Controls
- E Horn
- F Excavator arm controls
- G Dozer control lever
- H Ignition switch
- J Right console switches
- K Hand throttle
- L Instrument panel
- M Radio (if installed)
- N Operator seat
- P Control isolation lever
- Q Undercarriage track extension lever
- R Fire extinguisher (18z-1)
- S Fire extinguisher (19c-1)
- T Window washer bottle

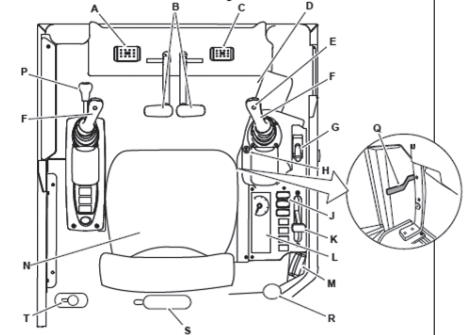

### Switch Panel – 18z-1, 19c-1

Fig 7

- A Graphic symbol
- B Light bar
- C 3 way position switch
- D 2 way position switch / momentary switch

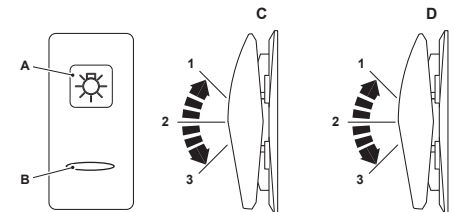

Fig 8



#### Work Lights

- 1 Off
- 2 On (Boom)
- 3 On (Boom & Cab)



#### Beacon

- 1 Off
- 2 On (Boom)



#### Window Wipers

- 1 Off
- 2 Intermittent/continuous/washer



#### Controls Isolation (2GO)

- 1 Off
- 2 Activate/de-activate hydraulic controls



#### Bi-Directional and Hammer Mode Selector

- 1 Bi-directional mode – Double acting
- 2 Hammer mode – Single acting



## Cab & Switch Panel

### Operator Station Layout – 19c-1 EP

Fig 9

- A Track controls
- B Heater controls
- C Excavator arm controls
- D Ignition Switch
- E Dozer control lever
- F Switch panel
- G Hand throttle
- H Auxillary power socket
- K Radio (if installed)
- L Instrument panel
- M Operator seat
- N Control Isolation lever
- P Undercarriage track extension lever
- Q Fire extinguisher
- R Swing left/right
- S Auxiliary control
- T Window washer bottle

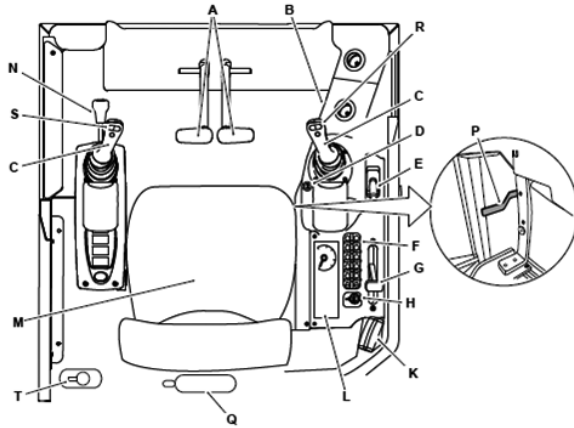

### Switch Panel – 19c-1 EP

Fig 10

- A Control Isolation Switch (2Go)
- B Aux 1 selection switch
- C Lift overload switch on/off switch
- D Worklights on/off switch
- E Wiper/ washer on
- F Auto-hydraulic warming switch
- G H+ mode selection switch
- H Aux 2 selection switch
- I Auto idle on/off switch
- J Beacon on/off switch
- K Q-hitch sequence switch

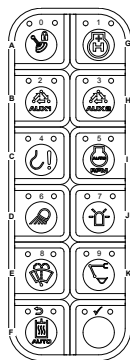

#### Key

- Black Text = Standard equipment
- Blue Text = Not Used

## Instrument Panel

### Instrument Panel – 18z-1, 19c-1

Fig 11

- A Fuel level gauge
- B Warning and indicator lamps

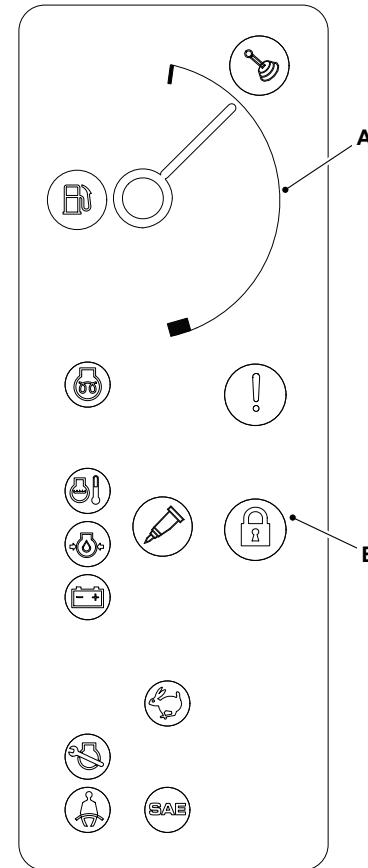

Fig 12

- Engine pre-heat
- Coolant temperature
- Engine oil pressure
- Battery charging
- Service due warning
- Low fuel indicator
- Seat belt
- High speed travel
- SAE active
- Master warning
- Immobilisers active
- Hydraulics active
- Aux 1 – single acting

## Instrument Panel

### Instrument Panel – 19c-1 EP

Fig 13

- A Fuel level gauge
- B Warning and indicator lamps

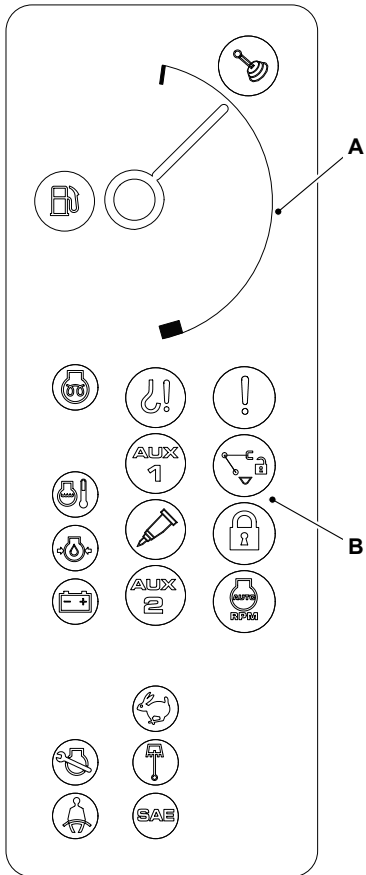

Fig 14

- Engine pre-heat
- Coolant temperature
- Engine oil pressure
- Battery charging
- Service due warning
- Low fuel indicator
- Seat belt
- High speed travel
- SAE active
- Master warning
- Immobilisers active
- Hydraulics active
- Quick hitch unlock
- Lift overload warning
- Aux 1 – double acting
- Aux 1 – single acting
- Aux 2 – low flow
- Swing active

## Foot Controls & Dozer Lever

### Swing Controls – 18z-1, 19c-1

Fig 15

- A Swing left
- B Swing right

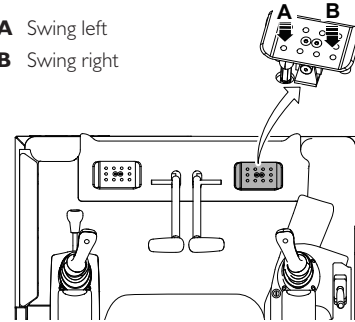

### Auxiliary Controls – 18z-1, 19c-1

Fig 16

- A Auxiliary pedal

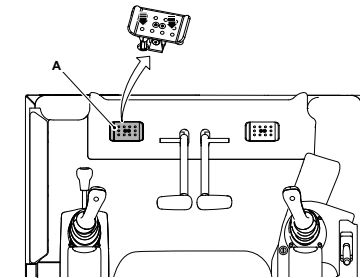

### Dozer Lever

Fig 17

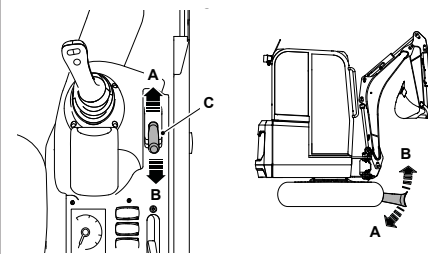

- A Lower the dozer
- B Raise the dozer
- C Control lever

### Retracting Undercarriage Lever

Fig 18

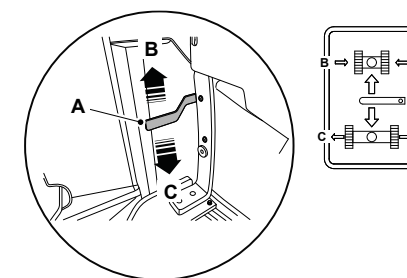

- A Track Extension Lever
- B Upward - Retract
- C Downward - Extend

## Joystick & Dozer Lever

### Swing Controls – 19c-I EP

Fig 19

- A Swing left
- B Swing right
- C Swing thumb wheel control
- D Change over button

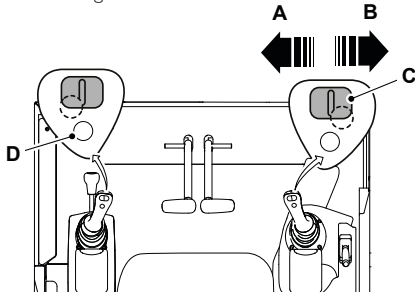

### Dozer Lever

Fig 21

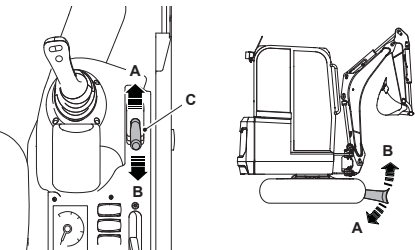

- A Lower the dozer
- B Raise the dozer
- C Control lever

### Auxiliary Controls – 19c-I EP

Fig 20

- A Tilt/grab changeover for tilt-rotator
  - B Boom swing/Aux change over button
  - C Thumb wheel control – Aux 2 (Low flow)
  - D Continuous flow button – Hammer circuit
  - E Thumb wheel control – Aux 1 (High flow)
- Note: A & D located underside of joystick

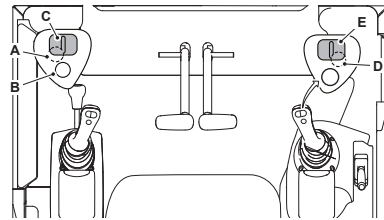

### Retracting Undercarriage Lever

Fig 22

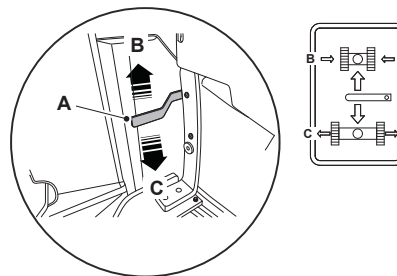

- A Track Extension Lever
- B Upward - Retract
- C Downward - Extend

## Start Up Sequence

### 1 Insert Isolator Key

Insert isolator key (A) and turn in a clockwise direction.

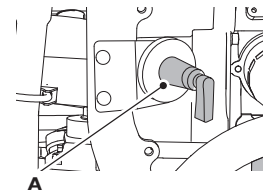

### 2 Raise LH Arm Rest

Ensure the hydraulic isolation lever (left hand arm rest) is in the raised position.

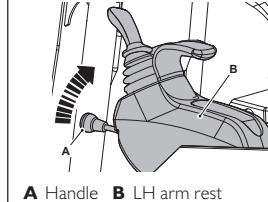

A Handle B LH arm rest

### 3 Engage Seat Belt

Engage seat belt (A) into latch (B) before starting machine.

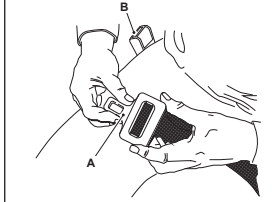

### 4 Engine Pre Heat

Turn ignition to position I (A) to pre-heat engine before start. Wait until pre-heat symbol (B) on instrument panel goes off.

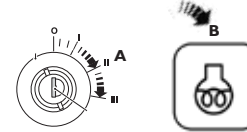

### 5 Disarm Immobiliser

If fitted disarm by entering PIN code using one of the below methods.



### 6 Start Machine

From ignition position I turn ignition to position 3 (A) to start the machine.

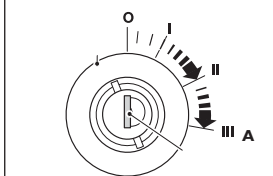

### 7 Lower LH Arm Rest

Lower the LH arm rest to activate the hydraulics.

*Note: If 2 GO enabled go to step 8, if not go to step 9*



A Handle  
B LH arm rest

### 8 Press 2 GO Button

If enabled press 2 GO button (A) to activate hydraulics. Instrument panel will illuminate (B) when active.



### 9 Operate Machine

All controls are now active and the machine is now ready to use.

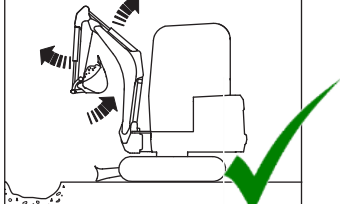



## Hydraulic Hitch Unlock Sequence (19c-1 EP only)

### Standard Attachments

#### 1 Start Unlock Process

To start quick hitch unlock process ensure hydraulics are live then press quick hitch sequence button (A).

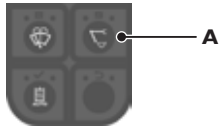

#### 2 Confirm Process

Instrument panel will indicate need to confirm process (A). To confirm process press 2 GO button (B).



#### 3 Boom LED Indicator

When the sequence is confirmed the LED on the boom will flash red (A).

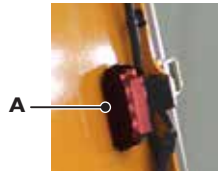

#### 4 Remove Attachment

To disengage the pivot pin, crowd attachment for 3 seconds then remove attachment.



#### 5 Change Attachment

Operate the machine to engage the jaw (A) with the attachment (B) and then full crowd the attachment to align latch.



#### 6 Lock Quick Hitch

To engage the lock on the quick hitch press one of the following two buttons and visually check hitch is locked.



## Mechanical Hitch Unlock System

### Standard Attachments

#### 1 Park Machine Up

Park the machine on firm level ground. Position the attachment (A) just above the ground and dozer (B) on the ground.

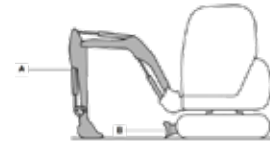

#### 2 Disconnect Attachment

Stop the engine, remove any connected hydraulic hoses and remove the locking pin.

#### 3 Insert tommy bar

Insert the tommy bar into the hole of the latch hook.

**A** Latch Hook **B** Tommy Bar  
**C** Hole

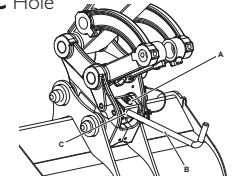

#### 4 Release Attachment

Apply downward pressure to the tommy bar to release the buckets rear pivot.

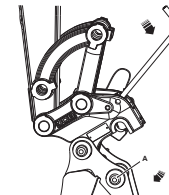

#### 5 Restart Machine

Start the engine, rest attachment on the ground and engage the hydraulics.

#### 6 Remove Attachment

Slowly roll the quickhitch in the direction of the arrow whilst raising the dipper to release the front pivot (A).

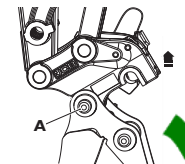

## Shutdown and Auxiliary Venting

### Shutdown Sequence

**1 Park Machine Up**

Park machine on solid level ground with the attachment (A) and dozer (B) on the ground.

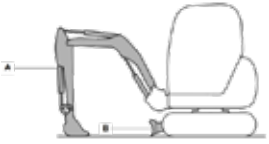

**2 Leave & Secure**

Switch off all switches. Leave machine using the handrails and footholds. Close & lock all doors and windows to secure machine.



**3 Isolate Machine**

Turn isolator key anti-clockwise and remove key.

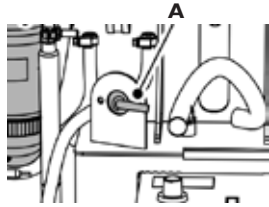

### Auxiliary Venting (Within 1 Minute of Shutdown)\*

**1 Lower LH Arm Rest**

While sitting in the operating station with engine off lower LH arm rest.

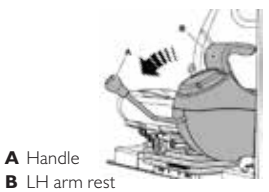

**A** Handle  
**B** LH arm rest

**2 Turn Ignition On**

Turn ignition to position 1 (A) so that the instrument panel and switches become active.

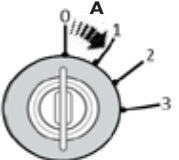

**3 Press 2 GO Button**

Press 2 GO button (A) to activate hydraulics. Instrument panel will illuminate (B) when active.



**4 Select Aux Circuit**

Enable aux function on top of the left control lever (A). Ensure symbol (B) or (C) is displayed.

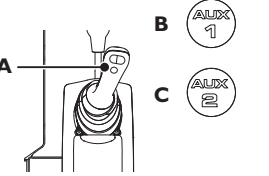

**5 Switching Circuits**

Change Aux mode between Aux 1 (A) and Aux 2 (B) using mode select switch on the right hand console.

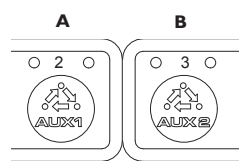

**6 Venting Aux Circuit**

Operate the roller switch fully in both directions to release stored pressure. Right hand (A) for Aux 1 and left hand (B) for Aux.

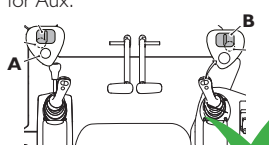

\*19c-1 EP only please refer to the operators manual for 19c-1 and 18z-1

## Maintenance Position

1. Park the machine on solid, level ground
  - I. Release the two track levers
  - II. Set the hand throttle lever to the idle position
2. Lower the dozer blade (A)
3. Lower the excavator so the attachment is flat on the ground

Fig 23

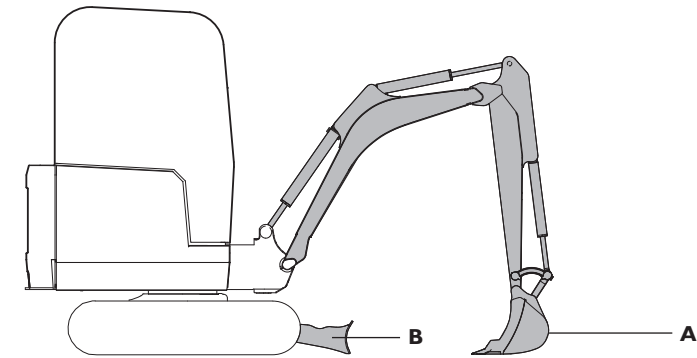

- A** Attachment flat on the ground  
**B** Dozer blade lowered to ground

4. Stop the engine
5. Discharge the hydraulic pressure (see aux venting operation)
6. Isolate the controls and remove ignition key
7. Isolate the battery to prevent accidental operation of the engine

## Service/Maintenance

Daily Checks (10h)	Check
Check engine for leaks and oil level	Visual check
Check engine coolant for leaks, contamination and level	Visual check
Check condition of cooling pack and system	Visual check
Check hydraulic oil level	Visual check
Check the condition of welded structure	Visual check
Check window washer fluid level	Visual check
Check condition of bodywork and framework	Visual check
Check condition of attachments / optional equipment	Visual check
Grease attachments / optional equipment as required	Lubricate
Check for excessive exhaust smoke	Visual check
Check fuel system for leaks & contamination	Visual check
Check operation of all services i.e. excavator, dozer etc.	Operate
Check operation of all electrical equipment i.e. horn, alarms etc.	Operate
Check the track and running gear operation	Operate
Check operation of the hour meter	Visual check

Weekly Checks (50h)	Check
Clean cooling pack	Clean
Drain water from water separator on fuel filter	Clean
Check condition of drive belt	Visual check
Check hydraulic hoses / pipework for leaks and damage	Visual check
Check condition of the rams	Visual check
Check the condition of the electrical wiring	Visual check
Clean the battery terminals	Clean
Check condition and tension of tracks	Visual check
Check presence of all pivot pin retaining bolts	Visual check
Grease slew ring bearing	Lubricate
Grease window and door hinges	Lubricate

## Access Covers – Service Items and Relays

Fig 24

- A Lock
- B Engine compartment cover
- C Handle

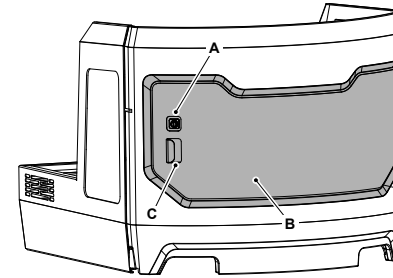

Fig 25

- A Fixings
- B Relay access cover

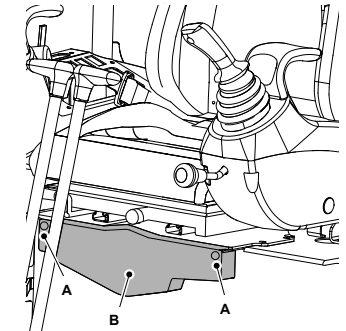
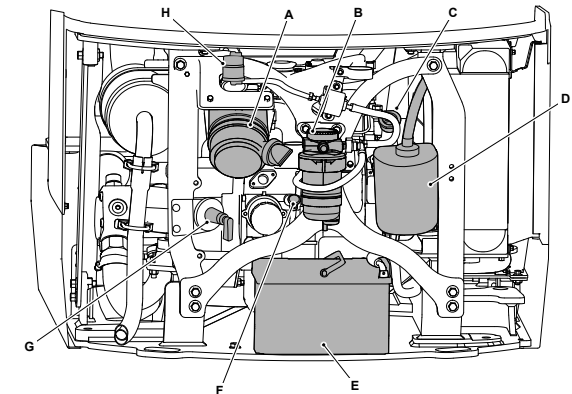

Fig 26

- A Air filter
- B Water separator
- C Oil filler cap
- D Coolant expansion bottle
- E Battery
- F Engine oil dipstick
- G Battery isolator
- H Fuel pre filter



## Access Covers – Fluid Levels and Fill

Fig 27

- A Hydraulic compartment cover
- B Lock

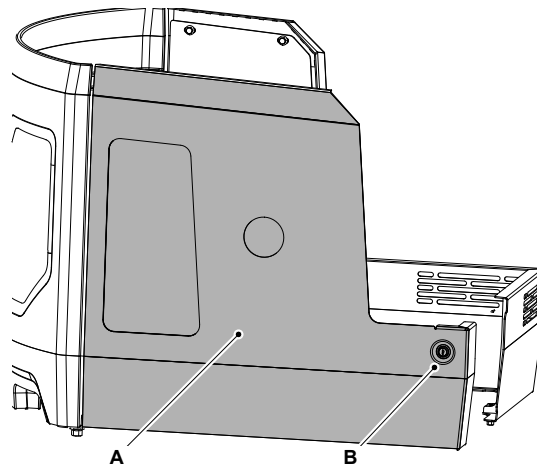
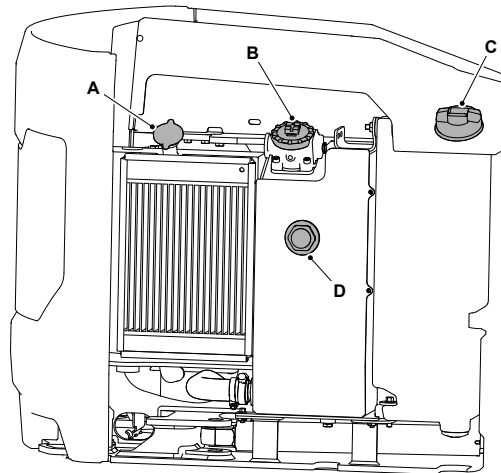

Fig 28

- A Radiator cap
- B Hydraulic tank filler cap
- C Fuel filler cap
- D Hydraulic oil level indicator



## Fluids and Lubricants

Item	Capacity	Fluid/lubricant	JCB Part Number	Container Size
Fuel Tank	20.5L	Diesel oil	–	–
Engine Oil (Stage 3A Perkins 403D-07)	2.5L	-30°C (-22°F) to 40°C (104°F): JCB Extreme performance 5W40	4001/2705	20L
Engine Coolant (Cab)	4.7L	JCB Antifreeze HP / Coolant / Water	4006/1120	20L
Engine Coolant (Canopy)	4.2L	JCB Antifreeze HP / Coolant / Water	4006/1120	20L
Track Gearbox (each)	0.3L	JCB Engine Oil HP SAE 30 (Not Multigrade)	4001/0305	20L
Track Idler Wheels	0.3L	JCB HP90 Gear Oil	4000/0305	20L
Track Rollers (bottom)	0.025L	JCB HP90 Gear Oil	4000/0305	20L
Hydraulic System	28L	-20°C (-4°F) to 46°C (114.7°F): JCB Hydraulic Fluid OP46	4002/2005	20L
Hydraulic Tank	15L	-20°C (-4°F) to 46°C (114.7°F): JCB Hydraulic Fluid OP46	4002/2005	20L
Slew Ring Bearing	As required	JCB HP Grease	4003/2017	0.4kg
Slew Ring Gear Teeth	As required	JCB Special Slew Pinion Grease	4003/1619	0.4kg
All Other Grease	As required	JCB MPL-EP Grease	4003/1501	0.4kg

JCB part numbers are liable to change and may also vary by region.  
For the latest information, always check with your dealer/distributor.

## Machine Attachments

Description	Weight (kg)	Intended Use	Hydraulic Requirements
Mechanical Quickhitch	13.7	Quick change of attachments	None
Hydraulic Quickhitch	22	Quick change of attachments	Quickhitch circuit
Bucket GP 150mm	20.2	General excavation / Bulk loading loose material	None
Bucket GP 230mm	22.2	General excavation / Bulk loading loose material	None
Bucket GP 300mm	24.4	General excavation / Bulk loading loose material	None
Bucket GP 400mm	28.7	General excavation / Bulk loading loose material	None
Bucket GP 460mm	30.3	General excavation / Bulk loading loose material	None
Grading / Ditching Bucket 760mm	36.8	Grading, finishing, landscaping and ditching	None
Grading / Ditching Bucket 1000mm	44.9	Grading, finishing, landscaping and ditching	None
Earth Drill – 1500Nm	63.8	Drilling 160mm – 900mm holes	1 Hi-Flow aux service
Breaker – HM1012T	107	Breaking up tarmac, concrete, rock	1x single acting aux service
Breaker –HMI100Q	129	Breaking up tarmac, concrete, rock	1x single acting aux service

ATTACHMENT WEIGHTS ARE A GUIDE ONLY, ALWAYS CHECK YOUR OWN ATTACHMENTS

## Troubleshooting/FAQs

Issue / FAQ	Resolution/Answer
<b>My machine will not start</b>	Ensure the start up sequence has been followed (Page 14). If machine still will not start contact dealer
<b>I can't activate the Hydraulics</b>	Here are some of the possible reasons: <ul style="list-style-type: none"> <li>• When the machine hydraulics are live and you lift the left hand pod you will need to re-select '2-GO' when the pod is returned to the down position.</li> <li>• The left hand pod is in the raised position.</li> <li>• There is a fault on the keypad.</li> <li>• Engine isn't switched on.</li> <li>• If there is an error on the machine and an error code is displayed on the LCD screen – which would inhibit the hydraulics.</li> </ul> If hydraulics still won't activate contact dealer
<b>Why is there an audible buzzer in the cab when I'm lifting a large load? (19c-1 EP only)</b>	The lift overload warning system has detected a load that is near the limits of the machine, reduce load to prevent machine overturning
<b>Can I disable the lift overload warning indicator when not object handling? (19c-1 EP only)</b>	To disable lift overload warning indicator when not object handling press button 'C' on the switch panel (refer to page 9)
<b>500hrs Greasing – Does it matter if greased every day?</b>	No, there is no impact on life of the pivot pins or bushes







JCB Sales Limited, Rokeceter, Staffordshire, United Kingdom ST14 5JP Tel: +44 1889 590312 Email: [salesinfo@jcb.com](mailto:salesinfo@jcb.com)  
Download the very latest information on this product range at: [www.jcb.com](http://www.jcb.com)

All rights reserved. No part of this publication may be reproduced, stored in a retrieval system, or transmitted in any form or by any other means, electronic, mechanical, photocopying or otherwise, without prior permission from JCB Sales. All references in this publication to operating weights, sizes, capacities and other performance measurements are provided for guidance only and may vary dependant upon the exact specification of the machine. They should not therefore be relied upon in relation to suitability for a particular application. Guidance and advice should always be sought from your JCB Dealer. JCB reserves the right to change specifications without notice. Illustrations and specifications shown may include optional equipment and accessories.