

Quick Start Guide

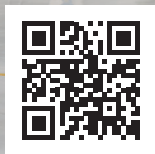

JCB Access
Electric Scissors



Disclaimer

- > This Quick Reference Guide is to provide quick and simple information to the Operator and does not include any health and safety aspects. In addition, because of our continual development of machines, features described in this Quick Reference Guide may differ from those on your machine. No errors and emissions be entirely ruled out.
- > This Quick Reference Guide **DOES NOT** replace the Operators Manual. You **MUST** read **ALL** the disclaimers and safety and other instructions in the Operators Manual before initially operating this product. Accordingly, no legal claims can be entertained on the basis of the data, illustrations or descriptions in this Quick Reference Guide.
- > This machine should not be operated by any person who isn't appropriately qualified or had the appropriate training.
- > Operation of this machine without periodic maintenance could cause it to malfunction. For more information please contact your JCB Dealer.

Index

Intended Use.....	4
Nomenclature.....	5
Tie Down Points	6
Lifting Points	7-8
Operating Capabilities	9
Ground Controls.....	10
Platform Controls	11
Emergency Controls.....	12
Operating from the Ground	13
Operating from the Platform.....	14
Extending Deck & Power to Platform.....	15
Machine Sensors.....	16
Daily Checks.....	17
Charge Level & Charging	18-20
Service Points	21
Diagnostic Codes	22-23

Intended Use

General

- > Machine Type – Electric Scissor
- > Self propelled machine with platform height of 15ft – 45ft (4.6m – 13.8m)
- > Lead acid or lithium battery powered

Intended Use

- > Machine intended to be used in normal conditions as detailed in the operators manual
- > PPE may be required in certain applications/environments e.g. high silica concentration or asbestos
- > The machine should not be operated by any person without appropriate qualifications, training or experience of using this type of machine
- > Prior to use, the machines suitability should be considered with regards to the intended applications and any hazards which may be present

Nomenclature

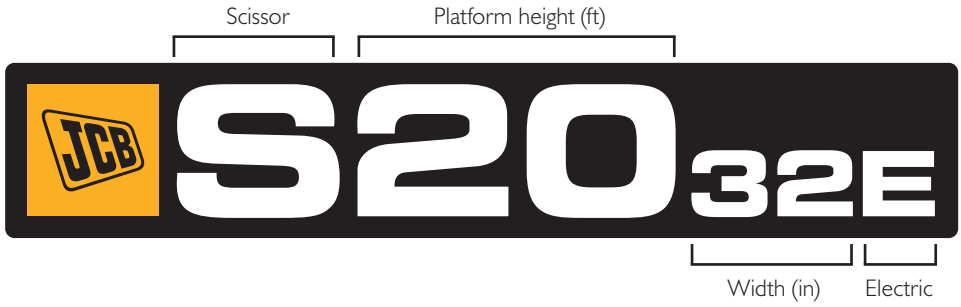

9 Models

SI530E

SI930E

S2032E

S2046E

S2632E

S2646E

S3246E

S4046E

S4550E

Tie Down Points

There are tie down points around all four corners of the machine. Look for this decal.



Make sure locking pins are engaged during loading/ transport of the machine.

Fig 1

A Lock Pin

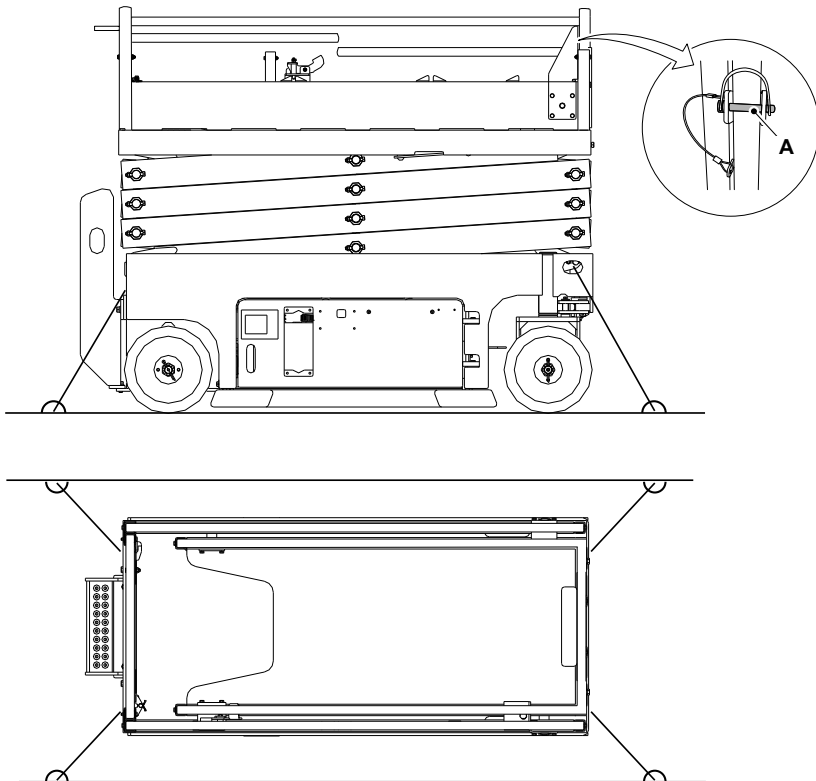

REFER TO OPERATORS MANUAL TRANSPORTING MACHINE

Lifting Points

Lifting by hoist

You must consider the location of the centre of gravity on the machine (see table on page 8), when you lift the machine

1. Make the machine safe with the platform lowered
2. Check the extension platform, controller and chassis parts are correctly secured
3. Remove any loose items from the machine
4. Use the correct length of hoisting rope to prevent damage to the platform base & guard rail
5. Make sure the hoist rigging is in the correct position. Adjust the hoist rigging to prevent machine damage and keep the machine in the level position.

Fig 2

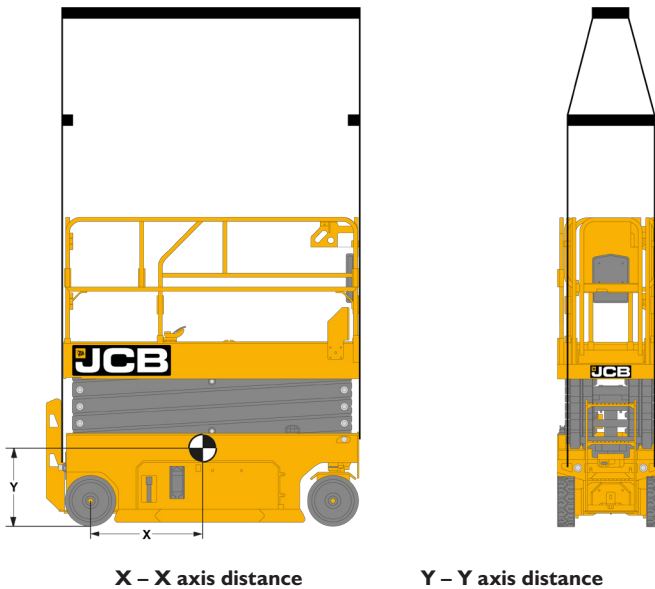

REFER TO OPERATORS MANUAL TRANSPORTING MACHINE

Lifting Points

Location of the centre of gravity

Machine Model	X Axis	Y Axis
SI530E	620mm	511mm
SI930E	604mm	540mm
S2032E	955mm	625mm
S2632E	956mm	672mm
S2046E	801mm	530mm
S2646E	806mm	570mm
S3246E	808mm	638mm
S4046E	815mm	676mm
S4550E	1,058mm	754mm

Lifting by forklift

Do not lift the machine from the side, lifting from the side may cause damage.

Forklift slots are located at the ladder side of the machine.

Fig 3

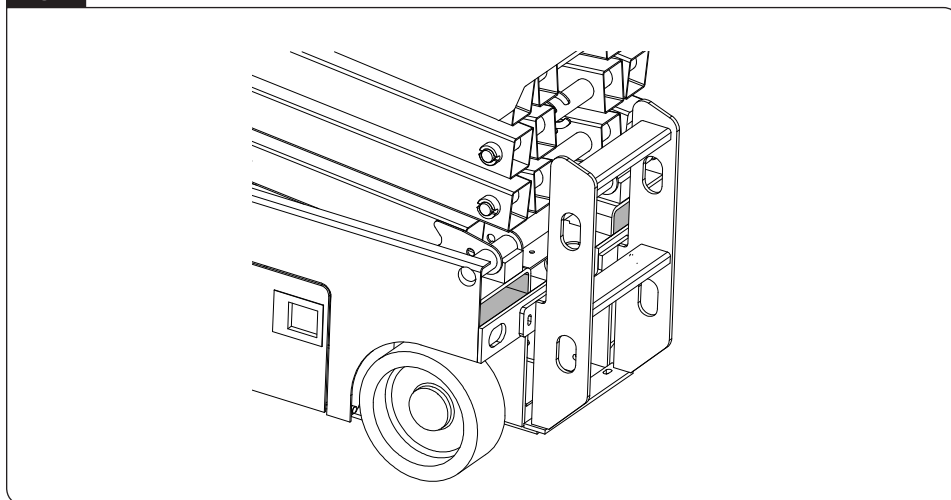

REFER TO OPERATORS MANUAL TRANSPORTING MACHINE

Operating Capabilities

The machine has been designed to operate in atmospheric temperatures between -20°C and 46°C .

The machine is designed to be used on flat level surfaces. The machine will operate with a front/back slope of up to 3° and a side slope of up to 1.5° . Exceeding these limits will trigger the tilt alarm.

The load capacity and wind rating of each machine can be found on the entry gate and also on the deck plate next to the handbook box.

Fig 4

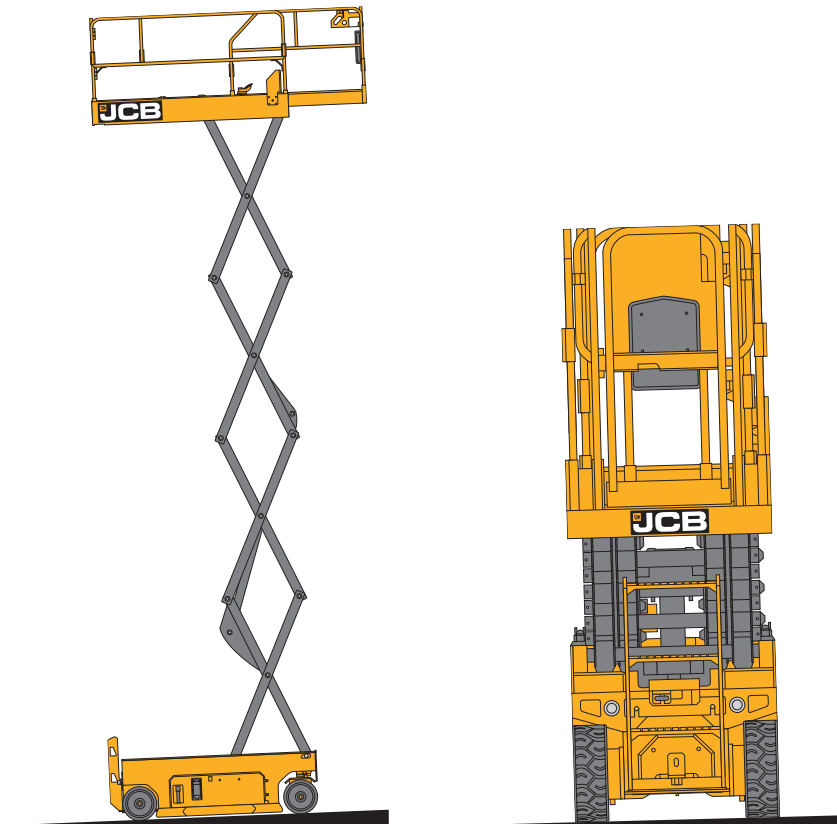

Ground Controls

Fig 5

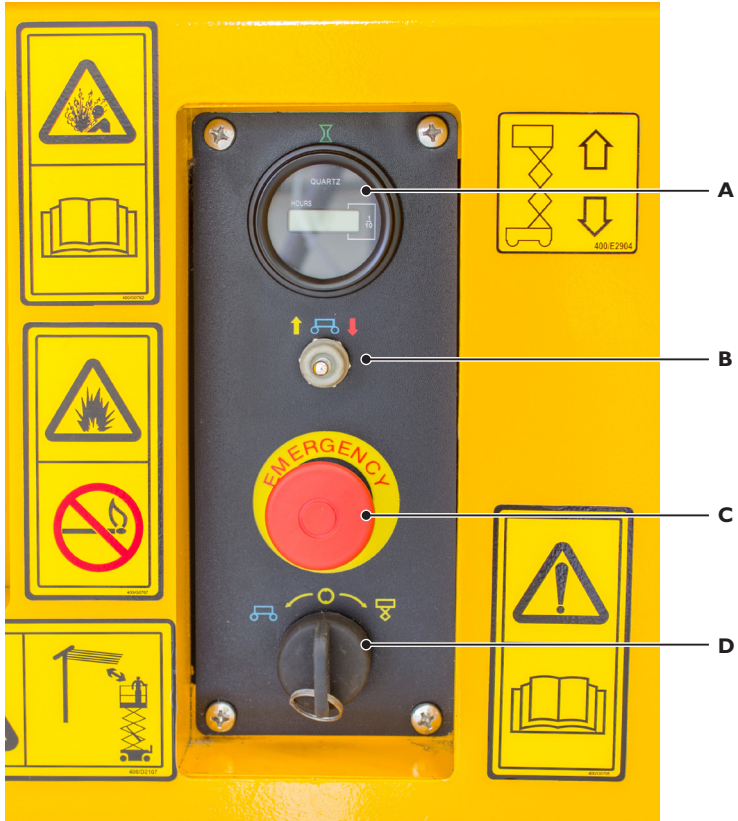

- A** Hourmeter
- B** Platform Raise / Lower Toggle Switch
- C** Emergency Stop
- D** Ground Controls / Off / Platform Controls Key Switch

Platform Controls

Fig 6

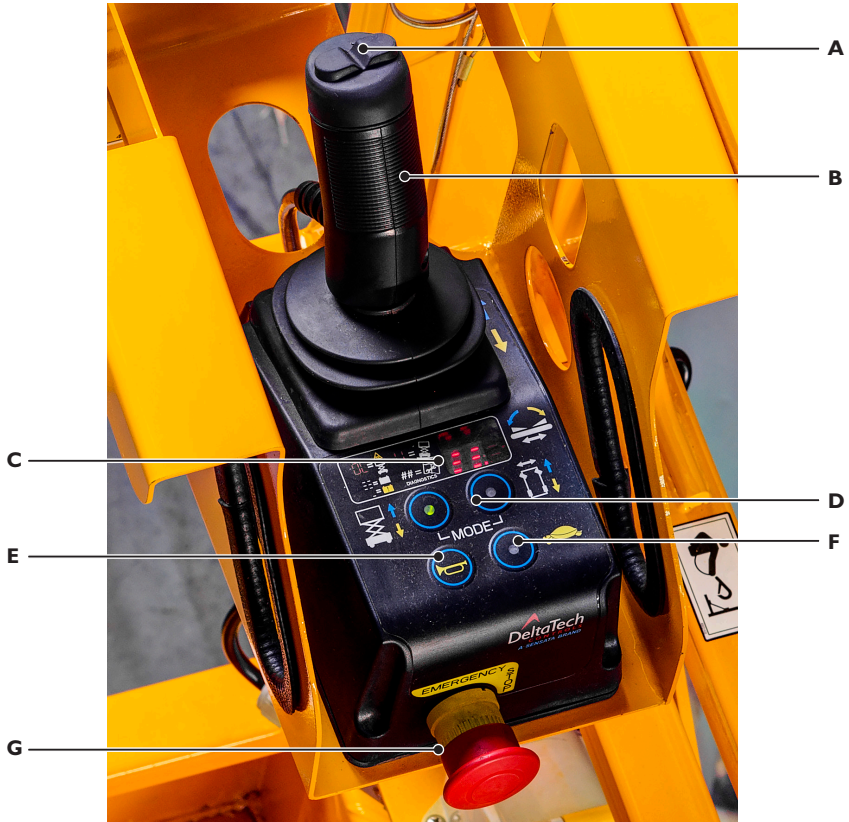

- A** L / R Steering
- B** Trigger Switch to enable operation
- C** Battery Level / Fault Code Display
- D** Platform / Drive Mode Buttons
- E** Horn
- F** Speed Select
- G** Emergency Stop

Emergency Controls

Fig 7



- A** Brake Release Lock
- B** Brake Release Pump
- C** Pull to lower

How to Release Brakes

1. Ensure machine can be controlled before releasing brakes
2. Push in brake release lock
3. Pump brake release until feels solid
4. Caution – machine is now un-braked
5. To reapply pull the brake release lock back out or operate any control on the joystick

Operating from the Ground

1 Connect Isolator

The isolator is located within the battery tray on the left hand side of the machine.



2 Pull E-Stops

Ensure both the ground controls and platform controls E-stops are released.



3 Switch Key Left

Turn the key switch left to enable the ground controls.



4 Toggle Switch

Use the toggle switch to raise or lower the platform as required.



Note: If the platform raise/lower fails to operate, ensure the key switch is in the correct position and all of the emergency stops have been pulled to release.

Operating from the Platform

1 Connect Isolator

The isolator is located within the battery tray on the left hand side of the machine.



2 Pull E-Stops

Ensure both the ground controls and platform controls E-stops are released.



3 Switch Key Right

Turn the key switch right to enable the platform controls.



4 Mode Select

Choose from either lift/lower or drive mode. Do not attempt to operate prior to charge status being shown.



5 Trigger & Joystick

Pull the trigger on the back of the joystick to enable operation.



6 Cradle Release

The cradle can be released from the platform by removing the bolt.



7 Operate Machine

If CH is shown on the platform controller, the key switch is in the wrong position. The switch must be on platform controls to use them. The machine will not operate whilst charging.



Extending Deck & Power to Platform

All JCB Electric Scissors are fitted with both power to platform and an extending deck as standard. The extending deck is operated by the pedal on the deck. The power to platform is used by the plug on the right hand side near the ladder and the power outlet in the basket (Photo for illustrative purposes, plugs and sockets region specific).



Machine Sensors

Safety systems on the electric scissor range rely on various sensors positioned around the machines linked to the on-board ECU.

Angle Sensor



Pressure Sensors

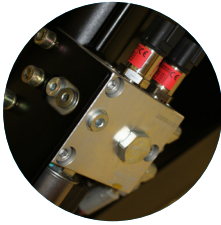

Limit Switches



Tilt Sensor



Pothole Protection Switch



Daily Checks

Check		
Operators Manual		Check Condition
Safety Decals		Check Condition
Hydraulic Oil		Check Level / No Leaks
Battery Electrolyte		Check Level / No Leaks
Electrical Harnesses		Check Condition
Welds		Check Condition
Machine Damage, Missing Parts		Check Condition
Guard Rails		Check Condition
Wheel Nut Split Pin		Check Condition
Tilt Sensor		Check Operation
Pothole Protection		Check Operation
Ground Controls: Emergency Stop		Check Operation
Ground Controls: Raise / Lower Toggle		Check Operation
Ground Controls: Key Switch		Check Operation
Emergency Lower Controls		Check Operation
Platform Controls: Emergency Stop		Check Operation
Platform Controls: Raise / Lower		Check Operation
Platform Controls: Horn		Check Operation
Platform Controls: Steering		Check Operation
Platform Controls: Drive and Brake		Check Operation
Limited Drive Speed (Check drive speed with platform raised)		Check Operation

Charge Level & Charging

The machine charge level is shown on the platform controller only when in platform mode. A series of red bars are used to show the charge level, 6 being full, 1 being empty.

Fig 8

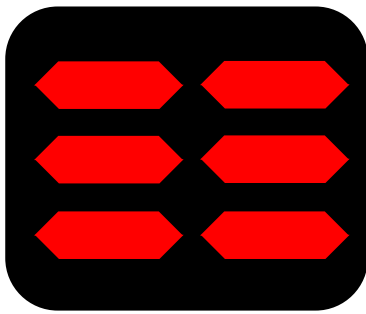

Full charge

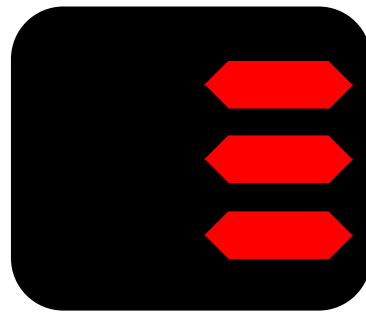

30% Remaining

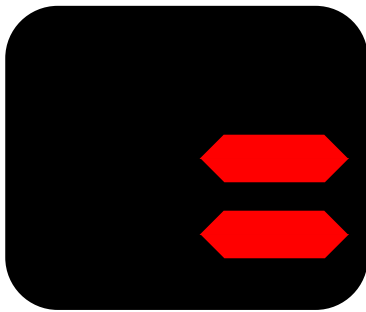

Charge battery low

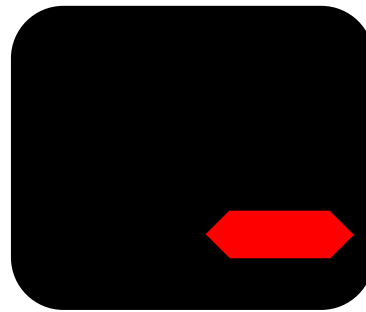

Battery too low. Charge now

Charge Level & Charging

The machine is charged using the plug on the left hand side, as viewed from the entry side of the machine. Once plugged in, green LED lights will start to flash on the charger, viewed through the charger viewing window.

Fig 9



- A Charge Point
- B Charger Viewing Window

Note: Only use the original charger installed to the machine with the original batteries. Charge the battery in a well ventilated place. Use an appropriate grounded industrial power supply with correct AC (alternating current) input voltage to charge.

If at any time a fault occurs when charging, three battery charge LEDs will blink at the same time. Refer to the operators handbook immediately.

Charge Level & Charging

The flashing LED indicates the charge level. When all three LEDs are solid, the machine is fully charged.

Fig 10

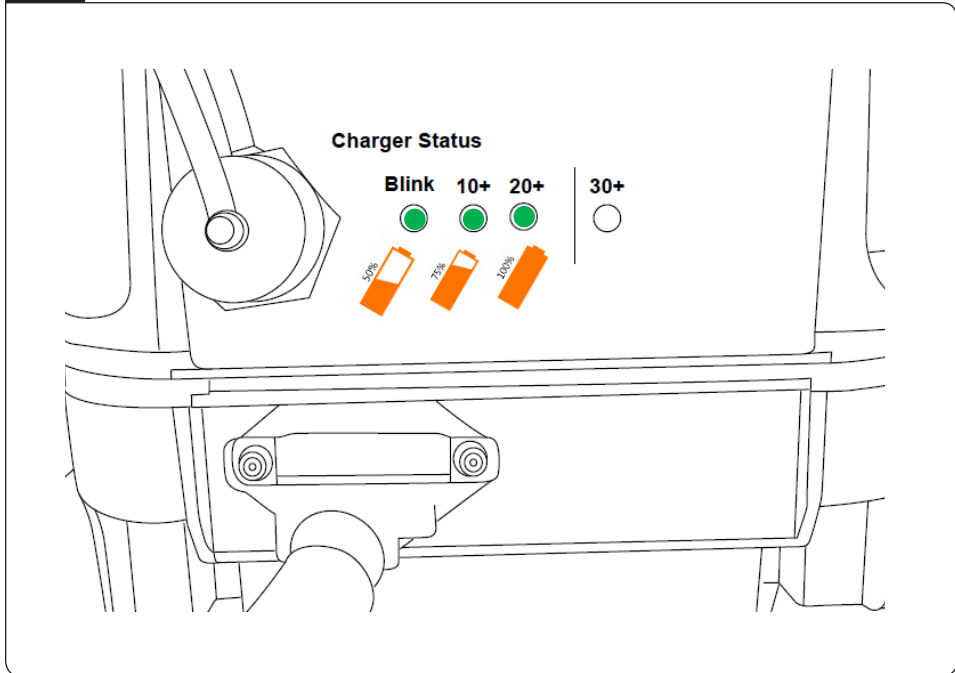

Note: Only use the original charger installed to the machine with the original batteries. Charge the battery in a well ventilated place. Use an appropriate grounded industrial power supply with correct AC (alternating current) input voltage to charge.

If at any time a fault occurs when charging, three battery charge LEDs will blink at the same time. Refer to the operators handbook immediately.

Service Points

Fig 11

Hydraulic Tray

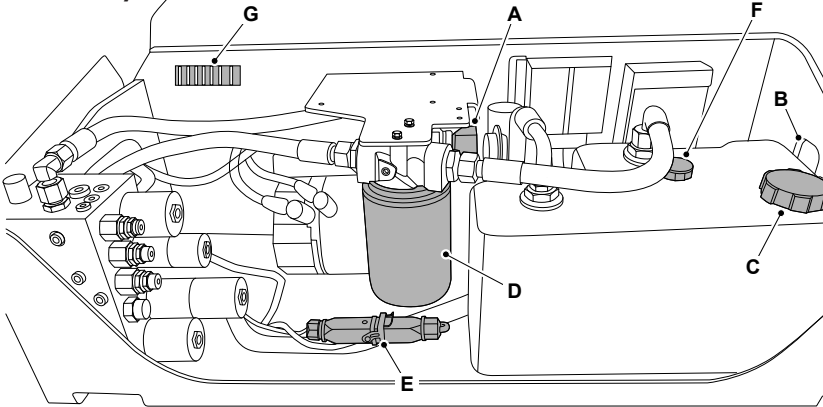

- A** Ignition Relay
- B** Hydraulic Level Viewing Window
- C** Hydraulic Oil Filter Cap
- D** Hydraulic Oil Filter
- E** Ground Control Connection
- F** Hydraulic Breather
- G** Secondary Fuses

Fig 12

Battery Tray

- A** Battery Isolator
- B** Primary Fuse (275A)
- C** Battery Charger
- D** Primary Fuse (20A)
- E** DC Contactor Resistor
- F** Charger Viewing Window
- G** DC Contactor

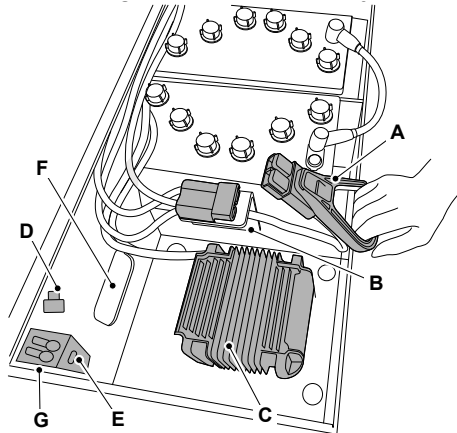

Diagnostic Codes



Diagnostic codes are shown on both the platform controller and through a viewing window on the hydraulic tray door.

Code	Description	Reaction	Instructions
01	System initialisation fault	Disables all motion	Restart the machine
02	System communication fault	Disables all motion	Restart the machine
03	Invalid option setting fault	Disables all motion	Restart the machine
04	Load sensing data fault	Warning only	Contact the dealer
12	Chassis up or down switch ON at power-up fault	Disable chassis control	Contact the dealer
18	Pothole guard fault	Disable lift and drive	Check pothole protection has been deployed
31	Pressure sensor 1 fault	Disables all motion	Contact the dealer
32	Angle sensor fault	Disables all motion	Restart the machine
36	Limp mode	Lift slow to elevated speed	Check battery charge level
42	Platform left turn switch ON at power-up message	Diagnostic message only	Contact JCB dealer
43	Platform right turn switch on at power-up message	Diagnostic message only	Contact JCB dealer
46	Platform joystick enable switch on at power-up fault	Disable platform control	Contact JCB dealer
47	Platform joystick not in neutral at power-up	Diagnostic message only	Restart the machine

Diagnostic Codes

Code	Description	Reaction	Instructions
52	Drive forward coil fault	Disable lifting and driving	Check no controls are operated at start-up
53	Drive reverse coil fault	Disable lifting and driving	Contact JCB dealer
54	Lift up coil fault	Disable lifting and driving	Contact JCB dealer
55	Lift down coil fault	Disable lifting and driving	Contact JCB dealer
56	Right turn coil fault	Disable lifting and driving	Contact JCB dealer
57	Left turn coil fault	Disable lifting and driving	Contact JCB dealer
58	General brake coil fault	Disable lifting and driving	Contact JCB dealer
59	Parallel coil fault	Disable lifting and driving	Contact JCB dealer
60	Motor control wiring broken	Disable lifting and driving	Contact JCB dealer
61	MC eeprom fault	Disable lifting and driving	Restart the machine
62	MC mosfet short fault	Disable lifting and driving	Contact JCB dealer
64	MC wiring fault	Disable lifting and driving	Contact JCB dealer
68	Battery low voltage fault	Disable all motion	Check battery charge
69	MC throttle fault	Disable lifting and driving	Contact JCB dealer
70	MC main contactor coil short	Disable lifting and driving	Contact JCB dealer
71	MC main contactor weld fault	Disable lifting and driving	Restart the machine
72	MC main contactor driver fault	Disable lifting and driving	Contact JCB dealer
77	MC over temperature cut off	Disable lifting and driving	Contact JCB dealer
80	Over 80% load warning	Warning only	Check platform load
85	Pressure sensor 2 fault	Disable all motion	Contact JCB dealer
86	Down limit switch fault	Disable all motion	Restart the machine
87	Up limit switch fault	Warning only	Contact JCB dealer
90	Over 90% load warning	Warning only	Reduce weight in platform
99	Over 99% load warning	Warning only	Reduce weight in platform
OL	Overloaded platform	Disable all motion	Reduce weight in platform to enable movement
LL	Machine tilted beyond safe limits	Disable lifting and driving	Check the ground level
LF	Up/down control fault	Warning only	Restart the machine



JCB Sales Limited, Rocester, Staffordshire, United Kingdom ST14 5JP Tel: +44 1889 590312 Email: salesinfo@jcb.com
Download the very latest information on this product range at: www.jcb.com

All rights reserved. No part of this publication may be reproduced, stored in a retrieval system, or transmitted in any form or by any other means, electronic, mechanical, photocopying or otherwise, without prior permission from JCB Sales. All references in this publication to operating weights, sizes, capacities and other performance measurements are provided for guidance only and may vary dependant upon the exact specification of the machine. They should not therefore be relied upon in relation to suitability for a particular application. Guidance and advice should always be sought from your JCB Dealer. JCB reserves the right to change specifications without notice. Illustrations and specifications shown may include optional equipment and accessories.

9818/3000