



Tracked Excavators
210X 220X



Disclaimer

- > This Quick Start Guide is to provide quick and simple information to the Operator and does not include any health and safety aspects. In addition, because of our continual development of machines, features described in this Quick Start Guide may differ from those on your machine. No errors and emissions be entirely ruled out. This Quick Start Guide DOES NOT replace the Operators Manual. You MUST read ALL the disclaimers and safety and other instructions in the Operators Manual before initially operating this product. Accordingly, no legal claims can be entertained on the basis of the data, illustrations or descriptions in this Quick Start Guide. This machine should not be operated by any person who isn't appropriately qualified or had the appropriate training. Operation of this machine without periodic maintenance could cause it to malfunction. For more information please contact your JCB Dealer.

Index

Intended use.....	4
Static dimensions	5
Tie down points	6
Lifting points	8
Cab layout & controls	9
Start up sequence.....	17
Shutdown sequence	18
Hydraulic quick hitch.....	19
Lifting mode	20
Maintenance position.....	21
Service / maintenance schedule	22
Fluids & lubricants.....	26
Troubleshooting / FAQs.....	27
Your notes.....	29

Intended use

General

- > Machine Type – Heavy Excavator
- > Self propelled machine with a tracked undercarriage
- > 360° revolving upper structure with boom, dipper, bucket and slew mechanism

Intended Use

- > The machine is intended to be used in normal conditions for the applications and in the environmental condition as described in the operators manual
- > When used normally with a bucket fitted to the machine the work cycle consists of, digging, elevating, slewing and the discharging of material without movement of the undercarriage.
- > Applications include earthmoving, road construction, building and construction, landscaping and similar applications.
- > An excavator can also be used for object handling if it is suitably equipped with the relevant parts and systems.
- > The machine must not be used in the following scenarios because of the risk of overturning: used for forestry, used with attachments of unknown weight, used on surfaces of unknown stability. This list is not exhaustive.
- > If the machine is to be used in applications where there is a high silica concentration, risk due to materials containing asbestos or similar hazards, additional protective measures such as the use of PPE (Personal Protective Equipment) may be required.
- > The machine should not be operated by any person who does not have an appropriate level of qualification ,training or experience of use of this type of machine.
- > Prior to use of the machine, its suitability (size, performance, specification etc.) should be considered with regards to the intended application and any relevant hazards that may exist.

Static Dimensions

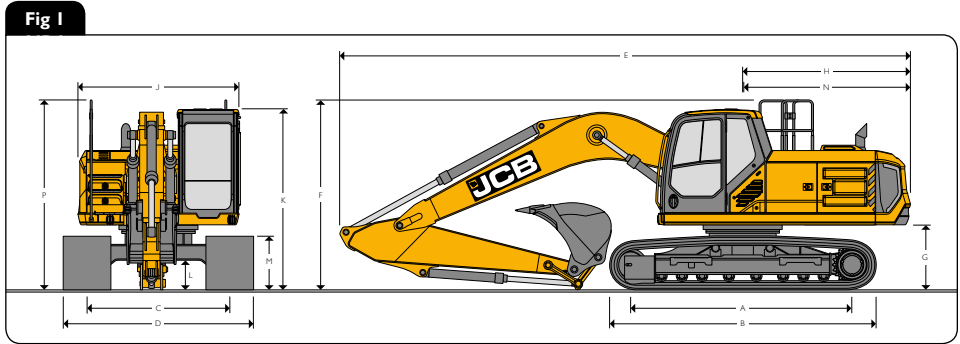

Dimensions in mm

Machine Type	210		220		
	LC	SC	LC	SLC	SC
Undercarriage options	LC	SC	LC	SLC	SC
A Track length on ground	3660	3370	3660	3660	3370
B Undercarriage overall length	4460	4170	4460	4460	4170
C Track gauge	2390	2170	2390	2170	2170
D Width over tracks (500mm trackshoes)	2890	2670	2890	2670	2670
D Width over tracks (600mm trackshoes)	2990	2770	2990	2770	2770
D Width over tracks (700mm trackshoes)	3090	2870	3090	2870	2870
D Width over tracks (800mm trackshoes)	3190	2970	3190	2970	2970
D Width over tracks (900mm trackshoes)	3290	-	3290	-	-
E Counterweight clearance			1077		
F Tail length			2813		
G Tail swing radius			2846		
H Width of upper superstructure			2700		
H Width of upper superstructure – Xd/Hd			2828		
I Height over cab			3030		
J Height over FOPS guard/Xd FOPS cage			3102		
J Height over grab rail			3170		
J Height over grab rail – folded handrail			2744		
K Ground clearance			485		
L Track height			885		
Boom option	Mono				
Dipper lengths	2.4m		3.0m		
M Transport length without bucket	9624 / 9597		9562 / 9540		
N Transport height without bucket	3200 / 3090		3086 / 3025		
Boom option	TAB				
Dipper lengths	2.4m		3.0m		
M Transport length without bucket	9622 / 9600		9410 / 9424		
N Transport height without bucket	3266 / 3225		3152 / 3170		
Boom option	LR				
Dipper lengths	6.4m				
M Transport length	12563				
N Transport height	3080				

Tie down points

Fig 2

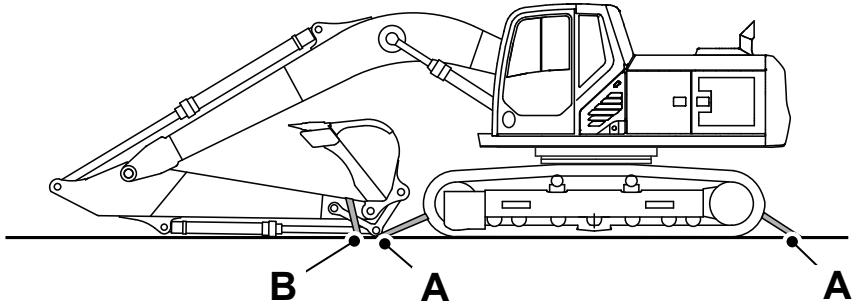

A Undercarriage tie down points

B Dipper tie down points

Standard undercarriage

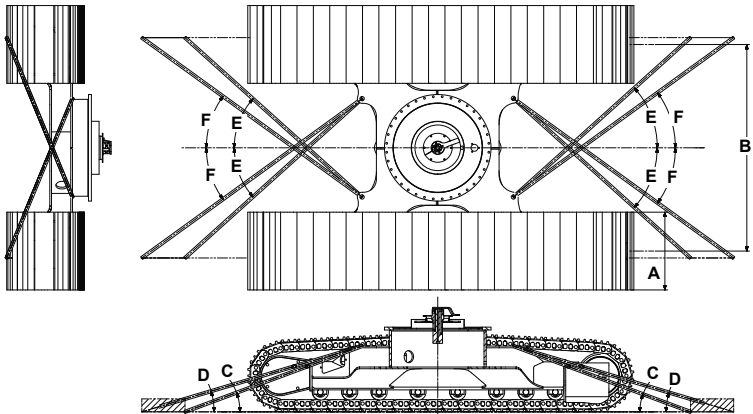

Tie down points

Fig 3

Undercarriage dozer option

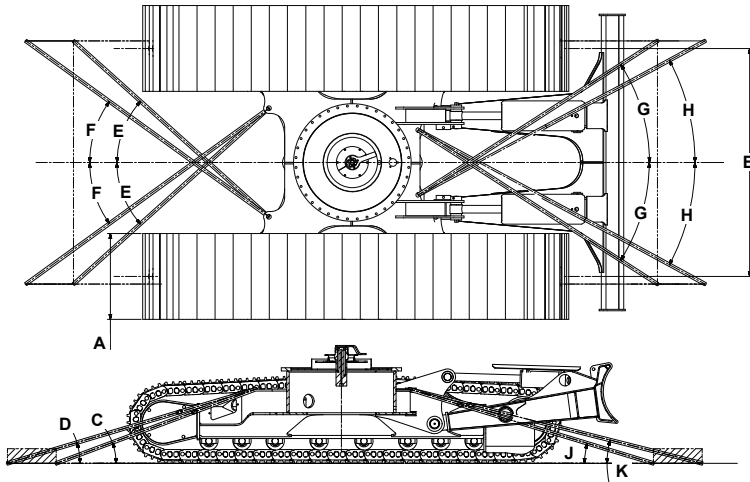

Tie down position decal

Undercarriage type	Track width	Running gear CL width	Angles in degree									
			A	B	C	D	E	F	G	H	J	K
210SC / 220SC / 220SCXD	800mm	2,170mm	20°	16.5°	41°	35°						
210LC / 220LC / 220LCXD / 220LCLR	900mm	2,390mm	20°	17°	42°	36°						
210NLC / 210NLC / 220NLCXD	700mm	1,990mm	18°	15.5°	39°	34.4°						
220SLC / 220SLCLR	800mm	2,170mm	18°	14.5°	38°	31°						
220LCD	900mm	2,390mm	20°	17°	42°	36°	33°	28.5°	62.5°	37.4°		
220SLCD	800mm	2,170mm	18°	14.5°	38°	34.4°	32°	28°	56°	36°		

Undercarriage type	Track width		Running gear CL width	
	Front tie down point	Rear tie down point	Front tie down point	Rear tie down point
210SC / 220SC	104kN	104kN	166kN	166kN
210LC / 220LC	107kN	107kN	172kN	172kN
210SLC / 210SLC	109kN	109kN	174kN	174kN
200LCD	118kN	120kN	189kN	192kN
200SLCD	118kN	113kN	189kN	181kN

Lifting points

Fig 4

- A Lifting points
- B Lifting decal

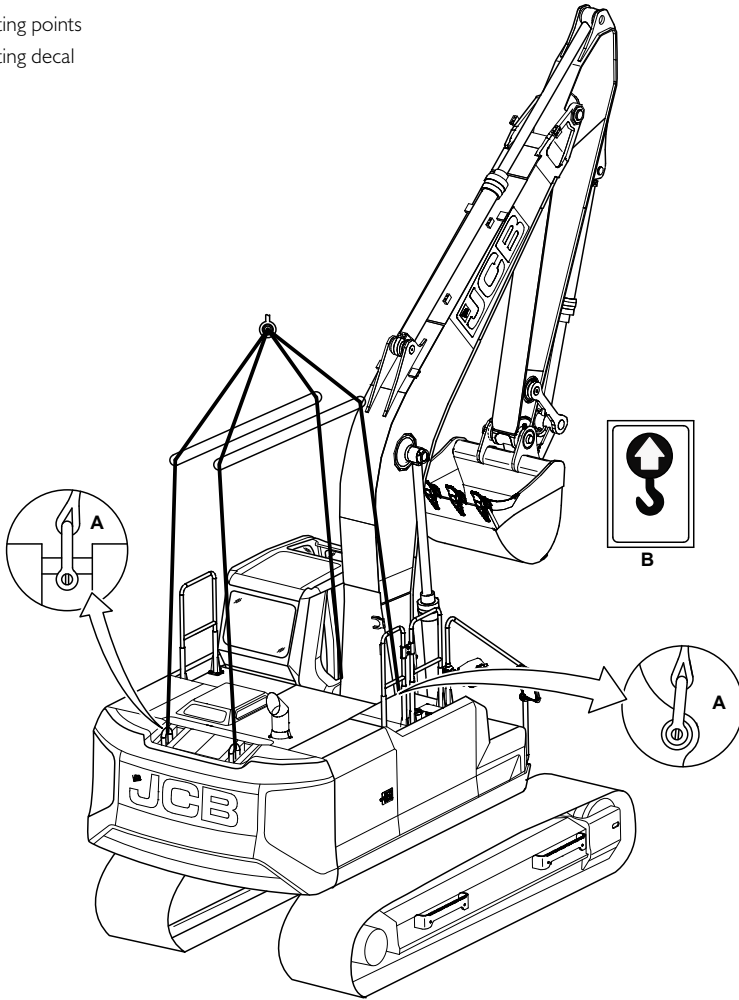

Note: The correct lifting positions are identified on the machine by their decals (B):

Cab layout & controls

Fig 5

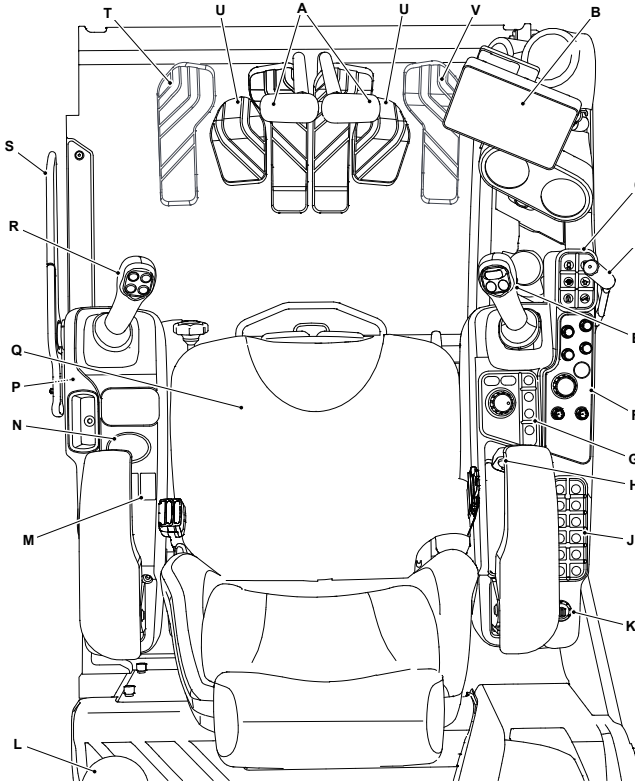

- | | |
|--|--|
| A Track controls | L Fire extinguisher (option) |
| B Display unit | M Option switches |
| C Keypad 1 | N Winter control panel (option) |
| D Dozer control (option) | P Left hand pod |
| E Right joystick | Q Operators seat |
| F Dial control panel | R Left hand joystick |
| G Display control panel | S Isolation lever |
| H Auxiliary power socket/media socket | T TAB (triple articulated boom) foot pedal (option) |
| J Keypad 2 | U Footrests |
| K Ignition switch | V Hammer/Auxiliary foot pedal |

Instrument panel

Fig 6

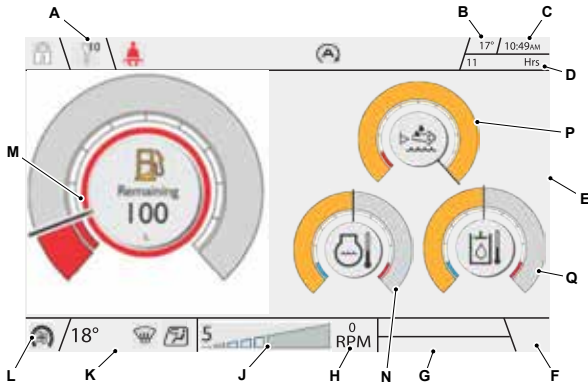

- | | |
|--|---|
| A Upper ribbon icons | J Power band |
| B Ambient temperature | K Lower ribbon HVAC (Heating Ventilation Air Conditioning) icons |
| C Clock | L HVAC/Fan speed |
| D Machine hours | M Fuel level gauge |
| E Camera screen (if camera mode selected) | N Coolant temperature gauge |
| F Volume or phone/media | P DEF fluid level gauge |
| G Source/detail information | Q Hydraulic oil temperature gauge |
| H Engine RPM (Revolutions Per Minute) | |

Fig 7

- A** Warning band
- B** Main band
- C** Fuel information
- D** Needle

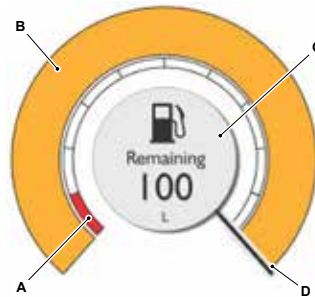

Rotary controller I

Fig 8

A Rotary media volume control:

Rotate clockwise to increase, anti-clockwise to decrease. Push to mute.

B Rotary media track/source control:

Rotate clockwise to skip forward, anti-clockwise to skip backwards. Push to select source.

C Engine start/stop button.

D Rotary wiper control:

Wiper off, intermediate 1, intermediate 2, continuous. Push to wash screen.

E Rotary worklight control:

Worklights off, worklights front, worklights rear, Worklights custom. Push to configure custom.

F Rotary machine operating powerband control:

Push to select heavy power band.

G Rotary HVAC (Heating Ventilation Air Conditioning)/heater temperature control:

Rotate clockwise to increase temperature, anticlockwise to decrease temperature. Push to select demister.

H HVAC/heater fan speed control:

Rotate clockwise to increase fan speed, anti-clockwise to decrease fan speed. Push to select vent mode.

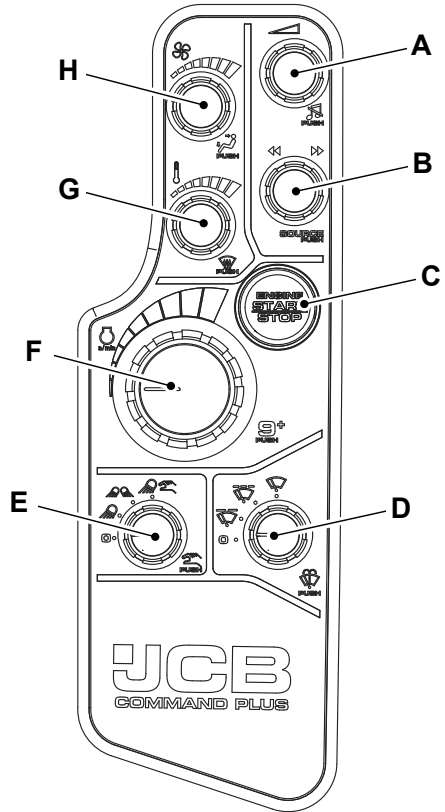

Rotary controller 2

Fig 9

- A** Quick hitch confirm button
- B** Lift mode on/off button
- C** Overload warning on/off button
- D** Quickhitch lock/unlock button
- E** Rotary control
- F** Back button
- G** Home button

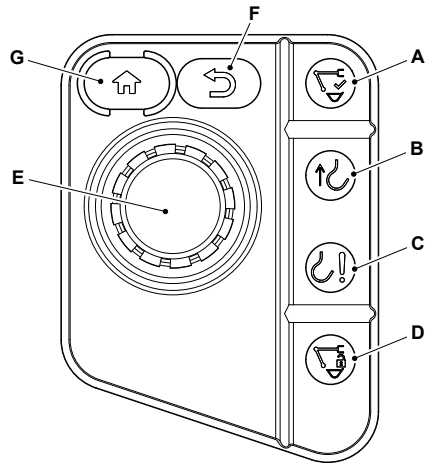

Keypad 1

Fig 10

- A** Slew lock on/off button
- B** Beacon on/off button
- C** Camera button
- D** Controls isolate button.
- E** Travel speed button
- F** Engine auto idle button

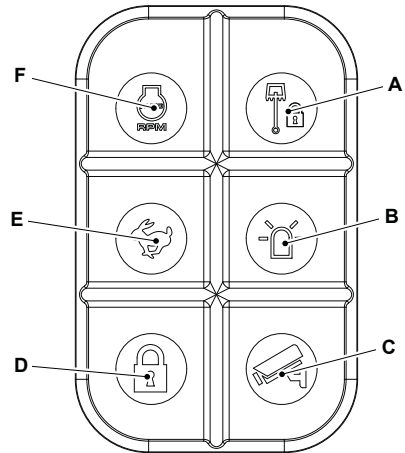

Keypad 2

Fig 11

A Call accept/reject/end button

Immobiliser key number 2

B Boom float button

Immobiliser key number 4

C Exhaust filter button, Immobiliser key number 6.
Press the button to initiate or defer SCR (Selective Catalytic Reduction)

D Aux 1 button. Immobiliser key number 8

E Aux 2 button. Immobiliser key number 0

F Not used

G Immobiliser back button

H Aux 2 button. Immobiliser key number 9

J Auxiliary venting, Immobiliser key number 7

K Slew smoothing button

Immobiliser key number 5

L Reverse fan button, Immobiliser key number 3.
When pressed the fan timer is overridden and the fan is reversed immediately for the time pre-set by the operator using the control box.

M Tool select button, Immobiliser key number 1

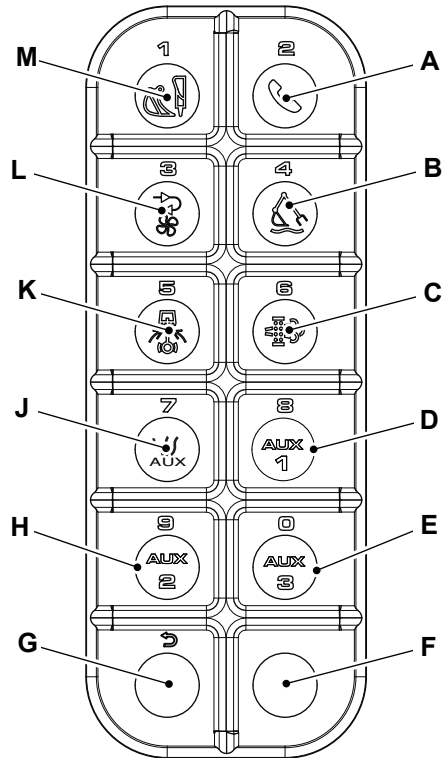

Pedals and controls

LH Joystick (ISO control pattern)

Fig 12

- A** Boom slew priority
- B** Horn
- C** Hot key
- D** Proportional Auxiliary Control high flow (option)
- 1** Left: Slew to the left
- 2** Right: Slew to the right
- 3** Forward: Move the dipper outwards
- 4** Backward: Move the dipper inwards

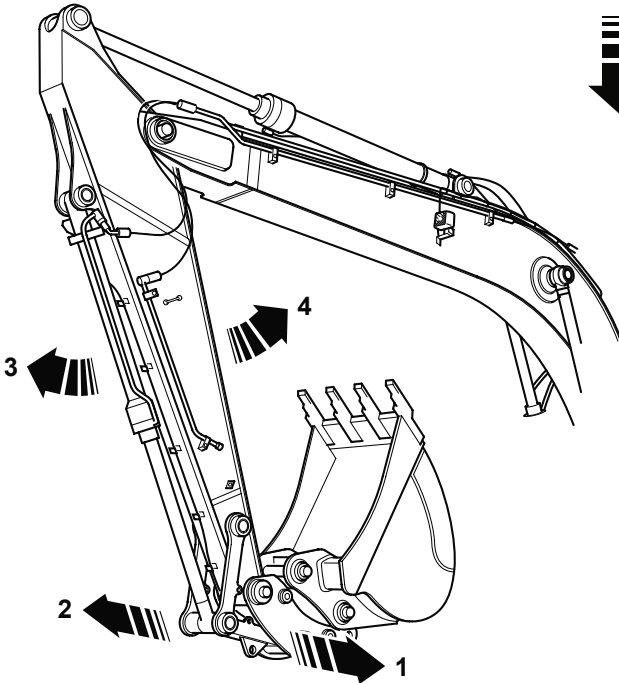
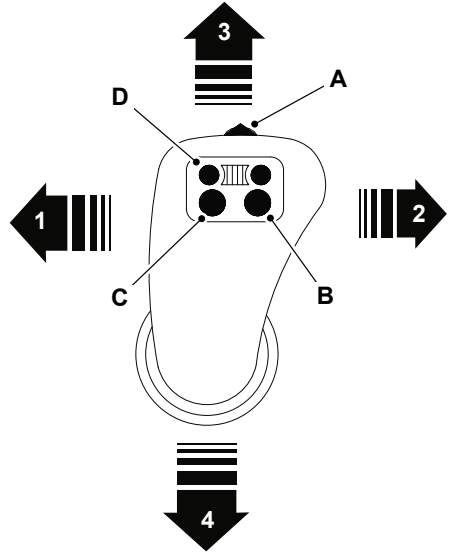

RH Joystick (ISO control pattern)

Fig 13

- A** Proportional auxiliary control low flow (option)
- B** 2 - speed tracking
- C** One touch engine idle
- D** Power boost
- 1** Backward: Raise the boom
- 2** Forward (lower the boom)
- 3** Left: Fill the bucket
- 4** Right: Empty the bucket

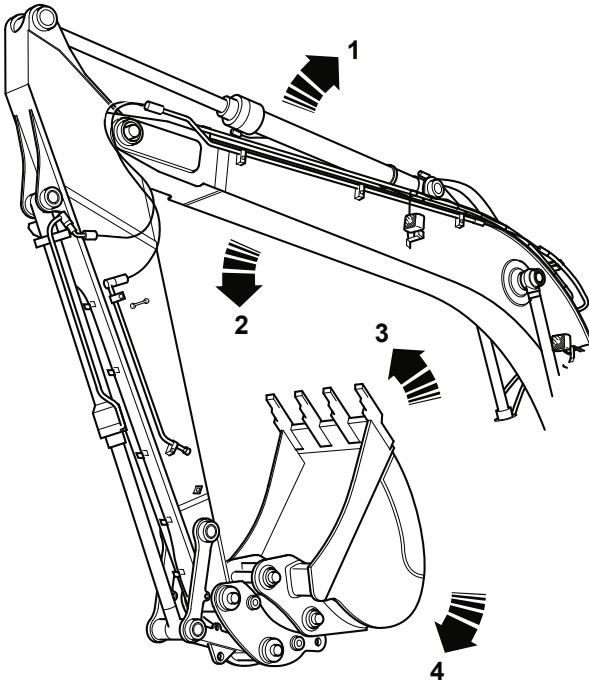
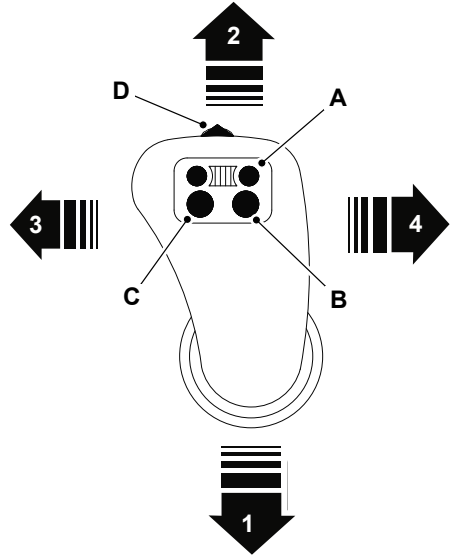

Pedals and controls

Track levers

Fig 14

- A** Left track lever
- B** Right track lever
- C** Right track pedal
- D** Left travel pedal
- E** Footrests

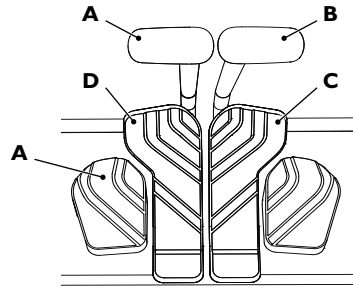

TAB boom controls (option)

Fig 15

- A** Pedal
- B** Ram
- 1** Heel end of pedal: Extend the ram
- 2** To end of the pedal: Retract the ram

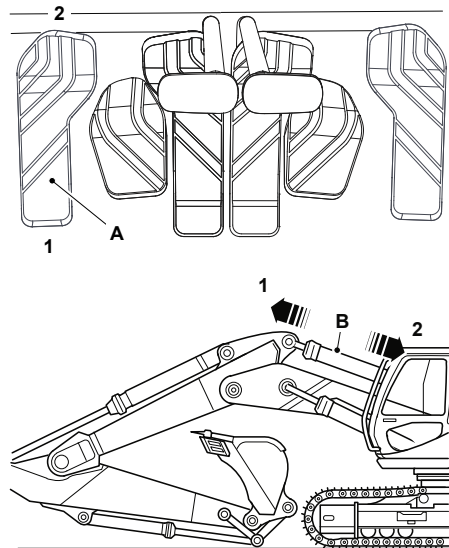

Start up sequence

1 Insert Isolator Key

Insert isolator key (A) and turn in a clockwise direction.

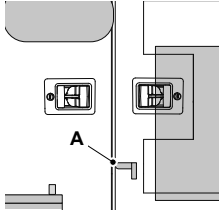

2 Check Isolation Lever

Ensure the hydraulic isolation lever is in the lower position (B).

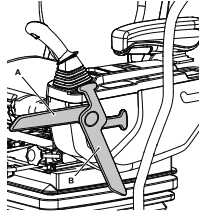

3 Engage Seat Belt

Engage seat belt (A) into latch (B) before starting machine.

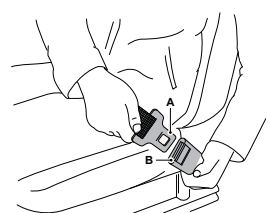

4 Engine Pre Heat

Turn ignition to position I (A).

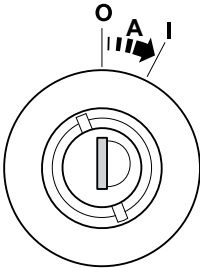

5 Disarm Immobiliser

If fitted disarm by entering PIN code using the 12 way keypad.

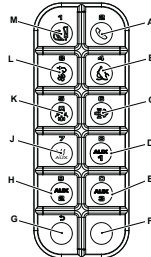

6 Start Machine

Hold down the Start/Stop button until the machine starts.

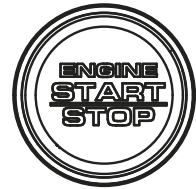

7 Raise LH Isolator lever

Raise the left hand isolator lever (A) to activate the hydraulics.

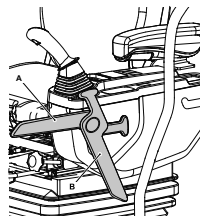

8 Press 2 GO Button

If enabled press 2 GO button (A) to activate hydraulics. Hydraulic isolation icon (B) will disappear from the dash when active.

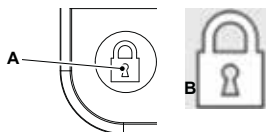

9 Operate Machine

All controls are now active and the machine is now ready to use.

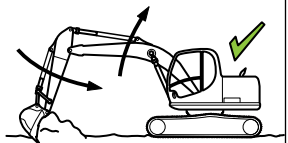

Shutdown and auxiliary venting

Shutdown sequence

1 Park machine up

Park machine on solid level ground with the attachment and dozer (if fitted) on the ground.

2 Leave and secure

Switch off all switches. Leave machine using the handrails and footholds. Close and lock all doors and windows to secure machine.

3 Isolate machine

Turn isolator key anti-clockwise and remove key.

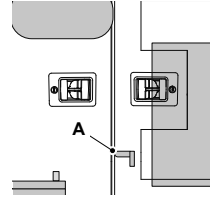

Auxiliary venting (within one minute of shutdown)

1 Turn ignition on

Turn ignition to position I (A) so that the instrument panel and switches become active.

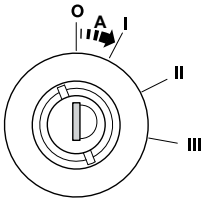

2 Raise isolator lever

While sitting in the operating station with engine off raise the isolator lever.

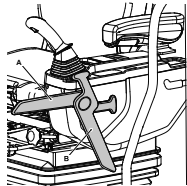

3 Press 2 GO button (if activated)

Press 2 GO button to activate hydraulics. Instrument panel will illuminate when active.

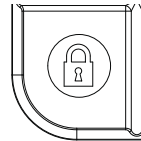

4 Operate aux switches

Continuously operate the auxiliary buttons/sliders (depending on machine configuration) A + B (page 14/15) on both joysticks for 5 seconds.

5 Rotate joysticks

Continuously rotate both joysticks for 5 seconds.

6 Auxiliaries vented

The auxiliaries should now be vented and pressure relieved. If it feels as though there is still pressure in the system, repeat from step 4.



Hydraulic quick hitch

Standard attachments

1 Start unlock process

To start quick hitch unlock process ensure hydraulics are live then press quick hitch sequence button (A).

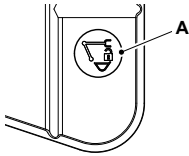

2 Confirm process

Switch (B) will flash and the buzzer will sound constantly for 5 seconds indicating confirmation is required. Press quickhitch confirm button (B). If not pressed within 5 seconds the process will need to be restarted.

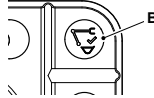

3 Indicator

When the sequence is confirmed the confirmation button will flash and a bucket crowd symbol will show on the display (B).

4 Remove attachment

To disengage the quickhitch jaws, crowd the attachment for 3 seconds. The attachment can now be removed.

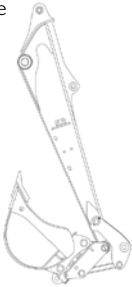

5 Change attachment

Operate the machine to engage the jaw (D) with the attachment (E) and then full crowd the attachment to align latch.

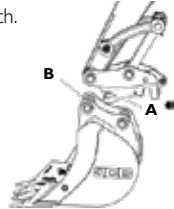

6 Lock quickhitch

To engage the lock on the quickhitch press the following button (B) and visually check hitch is locked.

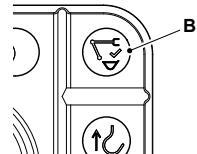

Specialised attachments

4a Crowd override

For large attachments where bucket crowding is not possible follow steps 1 to 3, and then hold rotary dial (C) for 10 seconds.

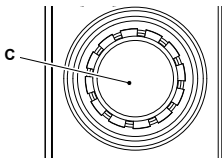

4b Remove attachment

An audible buzzer will sound after 10 seconds to indicate that the jaws of the quickhitch are open. The attachment can now be removed.

Specialised attachments are any attachment that when crowded fully could foul the boom/dipper.

Lifting mode

1 Mode selection

Activate button (A) on controller 2.

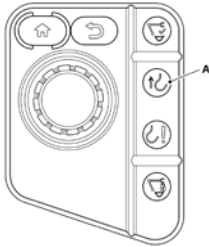

2 Power band adjustment

In lift mode the power band adjusts from A to B.



3 Overload alarm

Overload warning alarm is automatically activated, highlighted on screen by (A).

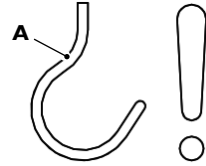

4 Autoidle de-activate

Autoidle de-activates when in lift mode, symbol B will not be on the screen.



5 Disable lift mode

To disable lift mode press button (A) on rotary controller 2.

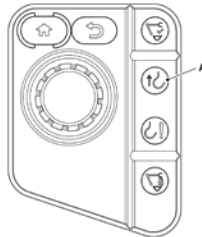

Lift overload warning system

1 The machine will remember the last setting after ignition on/ off.

2 When working with overload system enabled the display symbol (A) will illuminate red. This is because the machine has reached maximum lift capacity or the boom ram is fully retracted

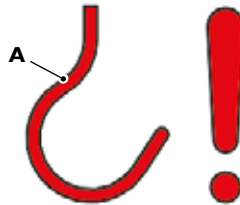

Maintenance position

Fig 16

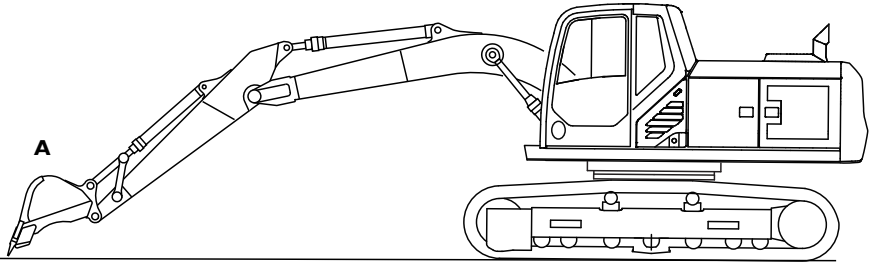

A Excavator End

1. Park the machine on solid, level ground, with the upper structure parallel to the undercarriage.
2. If necessary, lower the dozer blade.
3. Lower the excavator end to ground.
4. Stop the engine.
5. Remove the ignition key.
6. Release the hydraulic pressure and the tank pressure.
7. Isolate the battery to prevent the accidental operation of the engine.

Service/Maintenance Schedule

Daily Checks (10h)	Check
Check condition of attachments / optional equipment	Visual check
Grease attachments / optional equipment as required	Lubricate
Clean bodywork and framework	Clean
Check condition of bodywork and framework	Visual check
Check condition of cab/canopy including seat belt	Visual check
Check engine for leaks and oil level	Visual check
Check condition of drive belt	Visual check
Check fuel system for leaks and contamination	Visual check
Drain water from water separator on fuel filter	Clean
Check engine coolant for leaks, contamination and level	Visual check
Check condition of cooling pack and system	Visual check
Check hydraulic oil level	Visual check
Check window washer fluid level	Visual check
Check the condition of the fire extinguisher	Visual check
Check operation of all services i.e. excavator, dozer etc.	Operate
Check operation of all electrical equipment i.e horn, alarms etc.	Operate
Check operation of the hour meter	Visual check
Check the track and running gear operation	Operate

Weekly Checks (50h)	Check
Grease slew ring bearing	Lubricate
Clean cooling pack	Clean
Check condition and tension of tracks	Visual check
Check hydraulic hoses / pipework for leaks and damage	Visual check
Check condition of the rams	Visual check
Check the condition of the electrical wiring	Visual check
Clean the battery terminals	Clean
Check the operation of the battery isolator	Operate

Please refer to the operators handbook for a complete service and maintenance guide.

Service & Maintenance Points

Fig 17

- A** Air filter
- B** Fuse box
- C** Batteries
- D** Battery isolator
- E** Window washer fluid bottle
- F** Radiator(s)

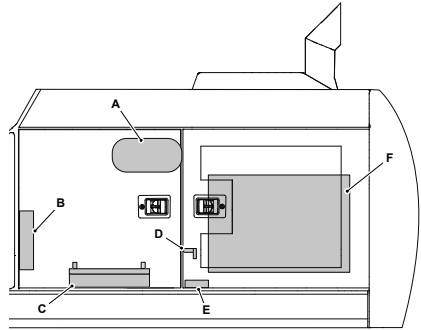

Fig 18

- A** Main fuel filter
- B** Engine oil filter
- C** Lubricity filter (option)
- D** Fuel sedimenter
- E** Hydraulic oil level indicator
- F** Fuel tap
- G** Water separator
- H** Fuel tank drain tap

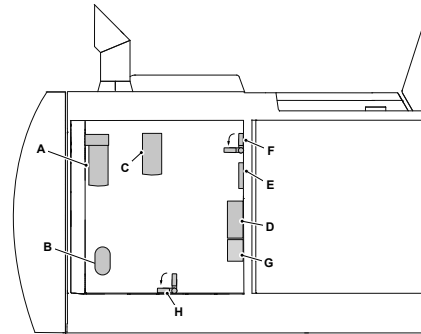
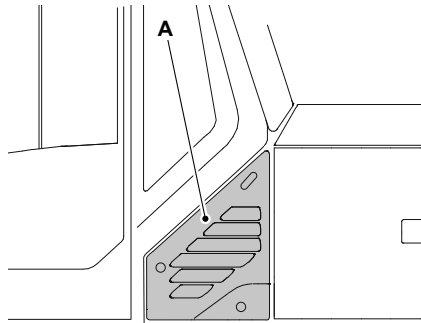

Fig 19

- A** Fresh air cab filter



Service & Maintenance Points

Fig 20

- A** DEF (Diesel Exhaust Fluid) filler cap
- B** Diesel fuel filler cap
- C** Hydraulic oil filler cap
- D** Engine oil dip stick
- E** Engine oil filler cap
- F** Coolant expansion tank
- G** Slew gearbox filler
- H** Slew gearbox dipstick
- J** Blower booster filter (option)
- K** Slew gear grease bath

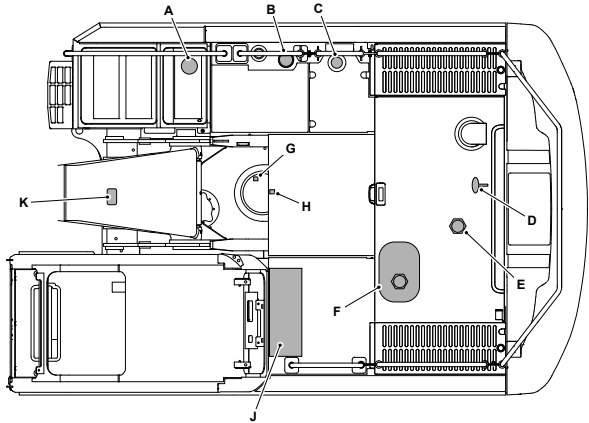
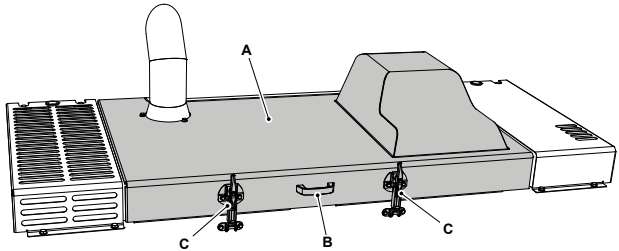

Fig 21

- A** Cover
- B** Handle
- C** Lock



Service & Maintenance Points

Upper step – DEF filler access

Fig 22

- A Latch
- B Cover
- C DEF tank filler cap

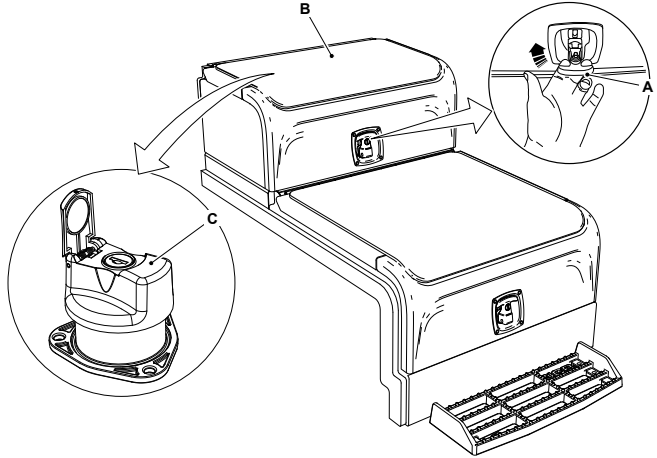

Lower step – Toolbox/refuel pump access (if fitted)

Fig 23

- A Fuel hose
- B Close-off valve
- C Switch

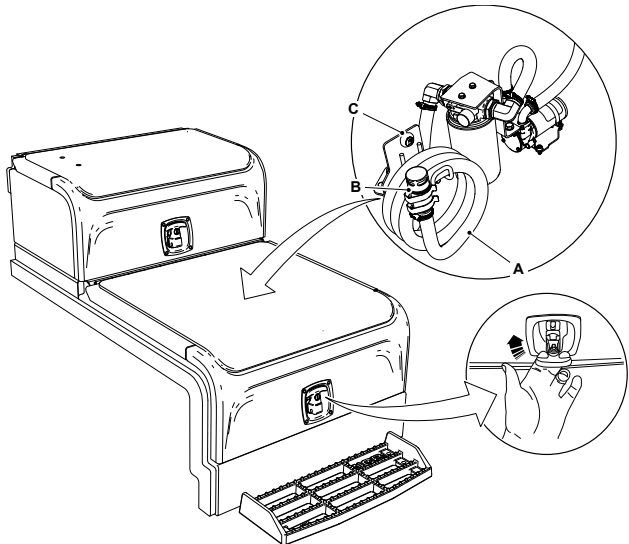

Fluids and Lubricants

Item	Capacity	Fluid/Lubricant	JCB Part Number	Container Size	Specification
Fuel Tank	387L	Diesel	400	-	Refer to 'Fuel'
DEF (Diesel Exhaust Fluid) Tank	47.7L	DEF	4009/0120	20L	Refer to 'DEF'
Engine (Oil) ⁽²⁾	20.4L	-30°C (-22°F) to 30°C (86.0°F) JCB Engine oil UP 5W/30	4001/3105	20L	API C.J-4
		-30°C (-22°F) to 46°C (114.7°F) JCB Engine oil UP 5W/40	4001/3405	20L	
		-15°C (5°F) to 46°C (115°F) JCB Engine oil UP 10W/30	4001/3005	20L	
Cooling System	38L	JCB Antifreeze HP/Coolant	4006/1120	20L	ASTM D3306, ASTM D4985, ASTM D6510, SEA (Society of Automotive Engineers) J1034, BS6580 (1992), AFNOR NF R15- 60
Track Gearbox (each)	3.5L	JCB HD90 Gear Oil	4000/0301	5L	
Slew Gearbox	8L	JCB HD90 Gear Oil	4000/0305	20L	
Track Rollers and Idler Wheels		JCB HD90 Gear Oil	4000/0305	20L	
Recoil Spring Cylinder		JCB Special HP Grease	4003/2017	0.4kg	
Hydraulic System	250L	JCB Hydraulic Fluid HP32, -20°C (-4°F) to 15°C (59°F)	4002/1024	200L	
		JCB Hydraulic Fluid HP46, -10°C (14°F) to 30°C (86°F)	4002/0803	200L	
		JCB Hydraulic Fluid HP68, 0°C (32°F) to 40°C (104°F)	4002/0701	200L	
Slew Ring Bearings	0.1kg	JCB Special HP Grease	4003/2017	0.4kg	
Slew Ring Gear Teeth	17kg	JCB Special HP Grease	4003/2006	12.5kg	
All other grease	As required	JCB Special HP Grease	4003/2006	12.5kg	

JCB part numbers are liable to change and may also vary by region. For the latest information, always check with your dealer/distributor.

Troubleshooting/FAQs

Issue / FAQ	Resolution / Answer
<p>My machine will not start</p>	<p>Ensure that the start-up sequence has been followed (Page 17).</p> <p>If the machine is fitted with an immobiliser make sure the correct pin has been entered.</p> <p>If the machine still will not start contact dealer.</p>
<p>I can't activate the Hydraulics</p>	<p>Make sure that the isolation lever is in the upper position (page 17).</p> <p>If the 2Go system is fitted, ensure that the isolation lever is in the upper position and the 2Go button has been pressed.</p> <p>There is an issue with the machine and an error code is present on the display, this would inhibit the hydraulics.</p> <p>If none of the above contact dealer.</p>
<p>How do I know if the hydraulic 2Go system is enabled/disabled?</p>	<p>If the system is disabled, the following symbol will appear on the dash upon start up.</p> <p>Contact dealer for more information on activating/deactivating 2Go system.</p> <div data-bbox="712 715 1012 895" style="border: 1px solid black; padding: 10px; text-align: center;">  </div>

Troubleshooting/FAQs

Issue / FAQ	Resolution / Answer
Can I open the quickhitch with the attachment on the ground?	The quickhitch can be opened with the attachment on the ground using the quickhitch override feature (Page 19).
Why is there an audible buzzer in the cab when I am lifting a large load?	The lift overload warning system has detected a load that is near the limits of the machine, reduce the load to prevent overturn (Page 20).
Can I disable the lift overload warning system when not object handling?	To disable the lift overload warning system when not object handling press the lift overload button on rotary dial 2 (page 20).
250 hour greasing – does it matter if greased every day?	No this has no adverse effect on the graphite impregnated bushes.
250 hour greasing – After the first 250 hours does the bush then need greasing daily?	No simply grease at each 250 hour interval .
250 hour greasing – After 250 hours does the bush need to be replaced?	No simply grease and continue work.
250 hour greasing – without daily greasing what cleans all the dirt out of the bush?	The machine is fitted with a one way seal stopping dirt entering the bush, but allows old grease out when greasing.
How do I switch between ISO/SAE joystick patterns?	The ISO/SAE changeover switch is located within the fusebox clearly labelled (if option fitted).
How do I pair my phone to Bluetooth?	<ul style="list-style-type: none"> • Switch the head unit source to Bluetooth. • Turn on Bluetooth on your mobile phone. • Search for the head unit and pair your phone. • Pairing code is 1234.
Can you deactivate the travel alarm?	Yes you can disable the travel alarm through the dash.
My cool box is blowing hot air.	The cool box works in conjunction with the HVAC system. If set to hot the cool box will warm, however the internal vent can be shut to prevent hot air from entering.



JCB Sales Limited, Rocoester, Staffordshire, United Kingdom ST14 5JP Tel: +44 1889 590312 Email: salesinfo@jcb.com
Download the very latest information on this product range at: www.jcb.com

All rights reserved. No part of this publication may be reproduced, stored in a retrieval system, or transmitted in any form or by any other means, electronic, mechanical, photocopying or otherwise, without prior permission from JCB Sales. All references in this publication to operating weights, sizes, capacities and other performance measurements are provided for guidance only and may vary dependant upon the exact specification of the machine. They should not therefore be relied upon in relation to suitability for a particular application. Guidance and advice should always be sought from your JCB Dealer. JCB reserves the right to change specifications without notice. Illustrations and specifications shown may include optional equipment and accessories.