



WHEEL LOADER | 403

Max. engine power: 26kW (36hp) Operating weight cab: 2642kg, canopy: 2555kg Standard shovel capacity: 0.4m³



THE POWER TO PERFORM.

THE JCB 403 IS DESIGNED TO OFFER TOTAL POWER AND VERSATILITY. ITS POWERFUL 36HP KUBOTA ENGINE, BOSCH REXROTH TRANSMISSION AND ZF AXLES COMBINE TO PUT PERFORMANCE AT THE VERY HEART OF THE MACHINE. IF YOU'RE LOOKING FOR A PRODUCTIVE COMPACT WHEEL LOADER, LOOK NO FURTHER.

Drivetrain performance.

1 Our two-speed hydrostatic Bosch Rexroth transmission makes it easy for operators to achieve precise machine movements even in cramped spaces. What's more, the driveline works in parallel with a combined braking/inching system on the footbrake. This offers superb multi-functioning and increased controllability during loading and rehandling.

2 Choose the differential lock option for 100% differential lock in both front and rear axles and your JCB 403 will provide ultimate traction and performance in soft, muddy ground.

3 The oscillating centre joint allows all four wheels to adjust to the contours of the ground and maintain maximum tractive effort at all times.

4 It's easy to detent hydraulic flow to the front using the auxiliary control lever. This provides a constant flow of up to 40 l/min for hydraulic attachments.

The new Smart Power option available on the 403 features a 19kW engine, offering improved fuel efficiency.



Loading productivity.

5 You can choose your perfect loader arm for ultimate productivity. The standard arm is ideal for general purpose work and high breakout/lift performance. Select the extended high lift arms for stacking and loading at height. Either way you'll get true parallel lift.

6 Two powerful lifting cylinders help the JCB 403 complete those day-to-day lifting and loading tasks with ease. This setup is aided by a perfectly balanced counterweight that provides excellent stability.

7 There's a range of quickhitches available, each one equipped with hydraulic pin locking as standard. This means that you can change attachments easily and safely.



STRENGTH YOU CAN RELY ON.

IT STANDS TO REASON THAT THE BIGGER THE WHEEL LOADER, THE TOUGHER IT IS. NOT NECESSARILY. THE JCB 403 BRINGS THE PREMIUM COMPONENTRY AND STRUCTURAL STRENGTH OF OUR LARGER MODELS TO A MUCH MORE COMPACT, MANOEUVRABLE PLATFORM.

Quality components.

1 We've hand-picked the very best core components for the JCB 403, including a Kubota engine, ZF axles and dropbox and Bosch Rexroth hydraulic transmission. They're all designed to work in perfect harmony, ensuring economical, reliable and productive performance.

2 The 403 is designed and built from scratch without compromise to deliver all the strength and power you need from an articulated machine.



Proven reliability.

3 This machine has benefited from a stringent testing programme that includes high stress loading of the chassis, loader arms and other key components. We've also subjected the transmission to thousands of typical working cycles.





Well protected.

- 4** A solid cast rear counterweight helps prevent impact damage. An additional 160kg counterweight is available for increased tipping load performance.
- 5** Protection plates underneath your 403 will shield the engine from impact damage.

6 Hydraulic hoses are neatly routed and clamped along the loader arms well away from any potential pinch points to guard against damage.

7 Heavy-duty axle feet absorb the immense stresses generated during continuous heavy material rehandling.

8 The folding canopy option features a box section frame design for maximum strength and utilises bronze bushes for added durability and cushioned stops to minimise rattling during machine operation.

Structural strength.

9 Loader arms are one of the hardest working components on any wheel loader, bearing the brunt of daily tasks. So the 403's patented parallel lifting arms are designed to distribute forces evenly into the front chassis, boosting strength and durability.

10 The 403's centre joint can withstand extremely high stress levels for maximum longevity.



COMFORT AND EASE OF USE.

THE MORE COMFORTABLE THE OPERATOR, THE MORE PRODUCTIVE YOUR OPERATION. THAT'S WHY THE JCB 403 IS DESIGNED TO OFFER YOU THE COMFORT OF A LARGER MACHINE IN A COMPACT PACKAGE. IT'S EASY TO ACCESS, INTUITIVE TO OPERATE, AND THE CENTRALLY POSITIONED OPERATOR'S SEAT OFFERS SUPERB VISIBILITY.

A comfortable operator.

1 The JCB 403 benefits from a comfortable and spacious cab. The operating position is designed for optimum all-round visibility, unhindered by things like exhausts and air filters.

2 Our tilting steering column is easy to adjust for an ergonomic driving position.

In complete control.

3 The 403 comes equipped with a new, ergonomically designed joystick control system, with optional joystick AUX controls (lever standard) for comfortable and intuitive operation. This means you can control all arm/auxiliary movements with your hand in one place.

4 You can manoeuvre quickly and easily with directional shuttle changes via the joystick mounted shuttle switch (FNR).

5 Switching between high and low travel speeds on the move takes just a click of a button located on the joystick.



EXCELLENT MANOEUVRABILITY.

1 Measuring under 2.2m in height and 1.1m in width (in the narrowest configuration), the compact new JCB 403 can access the very smallest operating environments.

2 Machine versatility is further increased thanks to the folding canopy option, this gives the operator the ability to quickly fold down the roof in under 40 seconds, allowing access into low height buildings or through doorways.

3 A compact wheelbase and 45° steering articulation angle help to ensure tight turning circles and superb manoeuvrability.

4 Because the 403 has an operating weight of just 2500kg, it can be easily towed to wherever you need it.

5 Choose between 20 or 30kph top speed to make travel times quicker.



SAFETY AND SECURITY.

BECAUSE SAFETY AND SECURITY ARE PARAMOUNT ON ANY SITE, THE JCB 403 IS DESIGNED TO PROTECT ITSELF, ITS OPERATOR, AND ANY BYSTANDERS AT ALL TIMES. GREAT VISIBILITY, MACHINE INFORMATION FEATURES AND NON-SLIP SURFACES ARE JUST THE START.

Safety first.

- 1** We've fitted an in-cab electronic two-stage quickhitch isolation system to prevent unintended release of attachments.
- 2** Operator safety is paramount to us, this is why all cab, canopy and folding canopy variants of the 403 are ROPS and FOPS certified.
- 3** Access steps are inclined and complemented by well positioned handles so that operators have three points of contact whenever they're entering or exiting the cab.
- 4** A battery cut-off switch protects your 403's power supply from damage or theft and also increases safety when carrying out routine servicing.



SERVICEABILITY.

WHEEL LOADERS NEED TO SPEND THE MAXIMUM AMOUNT OF TIME HARD AT WORK. WE'VE DESIGNED THE 403 TO DO JUST THAT, WITH LONG SERVICE INTERVALS AND QUALITY COMPONENTS.

Quick and easy servicing.

- 1 All daily checks and routine maintenance points are easily accessed under the large single piece bonnet.
- 2 The dash keeps JCB 403 operators well informed via a fuel gauge, hours display, high gear display, and all the usual warning lights.
- 3 The 48 litre fuel tank located in the front chassis can easily be refilled from ground level.

Dealer support.

- 4 All local JCB dealers have instant access to factory expertise and technical support to provide you with the maximum machine uptime. JCB's Global Parts Centres, meanwhile, deliver around 95% of all parts anywhere in the world within 24 hours.



VALUE ADDED.

JCB'S WORLDWIDE CUSTOMER SUPPORT IS FIRST CLASS. WHATEVER YOU NEED AND WHEREVER YOU ARE, WE'LL BE AVAILABLE QUICKLY AND EFFICIENTLY TO HELP MAKE SURE YOUR MACHINERY IS PERFORMING TO ITS FULL POTENTIAL.



1

1 Our Technical Support Service provides instant access to factory expertise, day or night, while our Finance and Insurance teams are always on hand to provide fast, flexible, competitive quotes.

2 JCB Assetcare offers comprehensive extended warranties and service agreements, as well as service-only or repair and maintenance contracts. Irrespective of what you opt for, our Maintenance teams around the world charge competitive labour rates, and offer non-obligation quotations as well as fast, efficient insurance repair work.



3

3 The global network of JCB Parts Centres is another model of efficiency; with 16 regional bases, we can deliver around 95% of all parts anywhere in the world within 24 hours. Our genuine JCB parts are designed to work in perfect harmony with your machine for optimum performance and productivity.



2

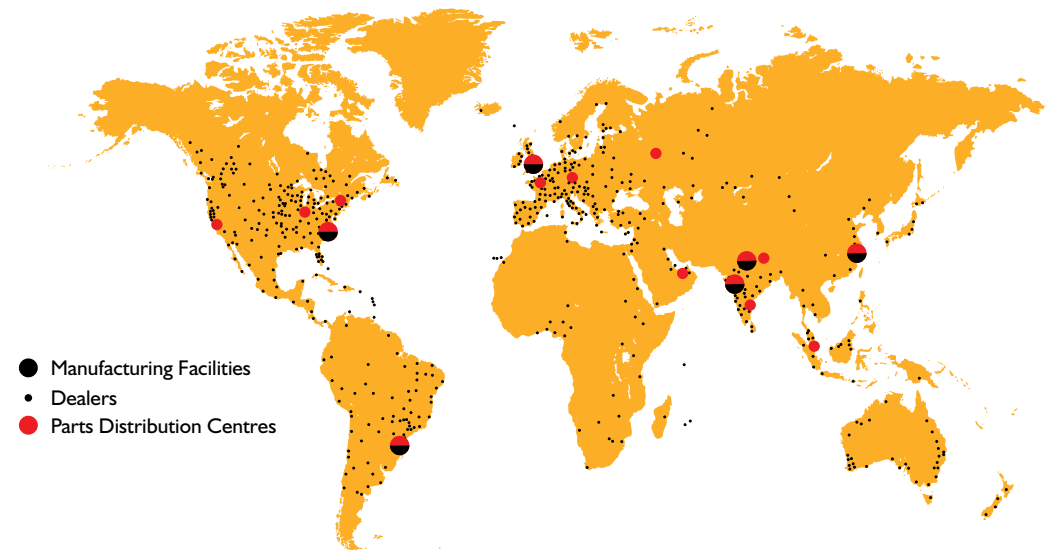

STATIC DIMENSIONS

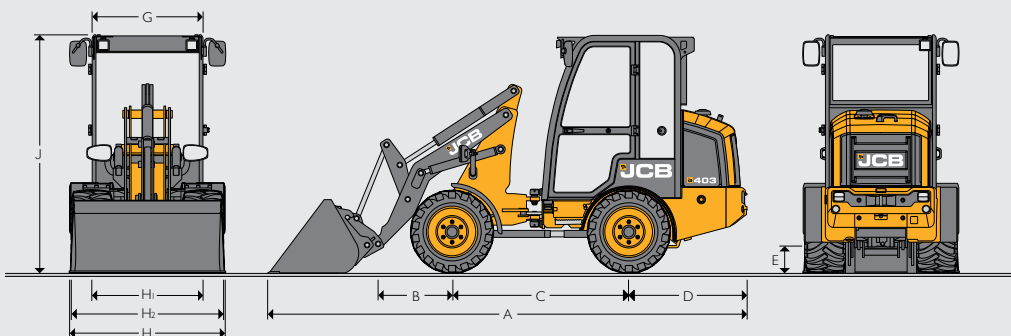

STATIC DIMENSIONS

		Standard Lift Arms		High Lift Arms		
		Agri Shovel	Construction Shovel	Agri Shovel	Construction Shovel	
A	Overall length	mm	4371	4174	4686	4491
B	Axle to pivot pin	mm	681		996	
C	Wheelbase	mm		1600		
D	Axle to counterweight face	mm		1083		
E	Minimum ground clearance	mm		241		
G	Width over cab roof	mm		1010		
H	Max. width over tyres – narrow / wide	mm		1080 / 1418		
H1	Max. wheel track – narrow / wide	mm		822 / 1018		
H2	Max. width over fenders – narrow / wide	mm		1088 / 1336		
J	Height over cab	mm		2200		
	Height over cab with beacon	mm		2340		
	Height over foldable canopy – raised	mm		2235		
	Height over foldable canopy – lowered	mm		1845		
	Max. front axle weight	kg		1224		
	Max. rear axle weight	kg		1824		
	Max. total weight (front and rear axles combined)	kg		3022		

TRANSMISSION

Type	ZF / Bosch-Rexroth				
	20kph		30kph		
Travel speed	Forward	Reverse	Forward	Reverse	
Hi range	kph	20	20	30	30
Low range	kph	8	8	12	12

TURNING CIRCLE

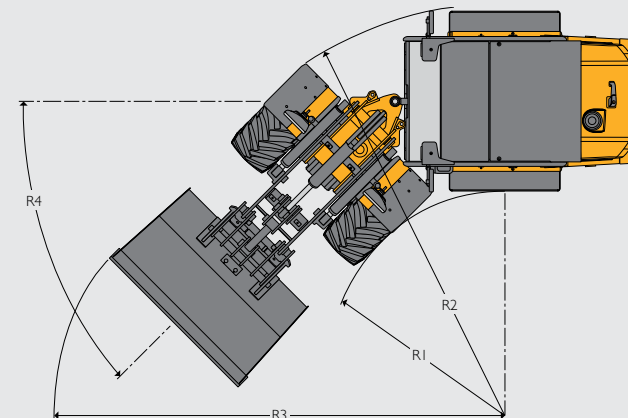

TURNING CIRCLE

Tyre		R1 (Inner Tyre Radius)	R2 (Outer Tyre Radius)
TR315 and SP HD	mm	1365	2825
MP567 and AS504	mm	1398	2793
MP567 and AS504	mm	1649	2542
Shovel type		R3 (Outer Shovel Radius)	
		Standard Arms	High Lift Arms
0.4m ³ Agricultural shovel	mm	3098	3383
0.5m ³ Agricultural shovel	mm	3219	3383
0.34m ³ Construction shovel	mm	3005	3161
0.43m ³ Construction shovel	mm	3143	3268
		R4 (Articulation Angle)	
	degrees	45	45

ENGINE

	403	403 Smart Power	
Make		Kubota	
Model		V1505	
Capacity	litres	1.498	
Aspiration		Naturally aspirated	
Cylinders		4	
Max. gross power to ISO 3046	kW (hp) @ 2700 rpm	26 (36)	19 (25)
Max. torque	Nm @ 2200 rpm	91.6	
Valves per cylinder		4	
Air cleaner		Donaldson FPG057502	
Fan drive type		Direct mount	
Emissions		Stage 3A	

LOADER DIMENSIONS

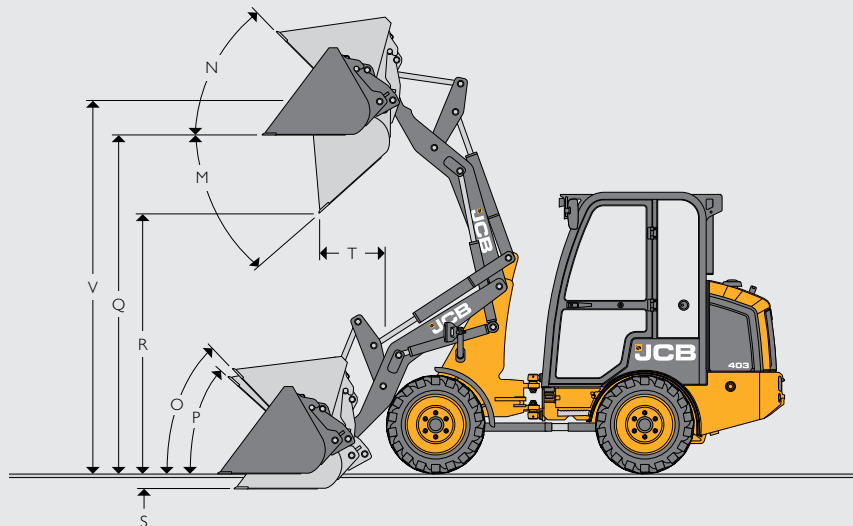

LOADER DIMENSIONS

		Standard Loader Arm				High Lift Loader Arm				
		Quickhitch		Quickhitch		Quickhitch		Quickhitch		
		Agricultural		Construction		Agricultural		Construction		
	Shovel mounting									
	Shovel type									
	Shovel capacity (SAE heaped)	m ³	0.4	0.5	0.34	0.43	0.4	0.5	0.34	0.43
	Shovel capacity (struck)	m ³	0.32	0.4	0.27	0.34	0.32	0.4	0.27	0.34
	Shovel width	mm	1200	1480	1200	1480	1200	1480	1200	1480
	Shovel weight	kg	132	153	133	154	132	153	133	154
	Maximum material density *	kg/m ³	1436	1124	1744	1351	1190	929	1440	1112
	Tipping load straight *	kg	1590	1564	1641	1615	1333	1308	1370	1346
	Tipping load full turn *	kg	1149	1124	1186	1162	952	929	979	956
	Payload *	kg	575	562	593	581	476	465	490	478
	Maximum breakout force	kN	12.6	12.6	16	16	12.6	12.6	16	16
M	Dump angle maximum	degrees	42	42	42	42	45	45	45	45
N	Roll back angle full height	degrees	45	45	45	45	47	47	47	47
O	Roll back at carry	degrees	46	46	46	46	46	46	46	46
P	Roll back at ground level	degrees	46	46	46	46	46	46	46	46
Q	Load over height	mm	2612	2612	2612	2612	2820	2820	2820	2820
R	Dump height (45 deg dump)	mm	2008	2008	2140	2140	2187	2187	2327	2327
S	Dig depth	mm	115	115	115	115	194	194	194	194
T	Reach at dump height	mm	506	506	359	359	568	568	434	434
V	Pin height	mm	2882	2882	2882	2882	3090	3090	3090	3090
	Reach maximum (45deg dump) - horizontal arm	mm	1769	1819	1644	1694	2117	2167	1992	2042
	Operating weight with canopy enclosure and wide industrial tyres (includes 75kg operator and full fuel tank)*	kg	2682	2703	2684	2704	2696	2717	2698	2718
	Weight for transport	kg	2607	2628	2609	2629	2621	2642	2623	2643

LOADER DIMENSIONS – FORK FRAME WITH FORKS

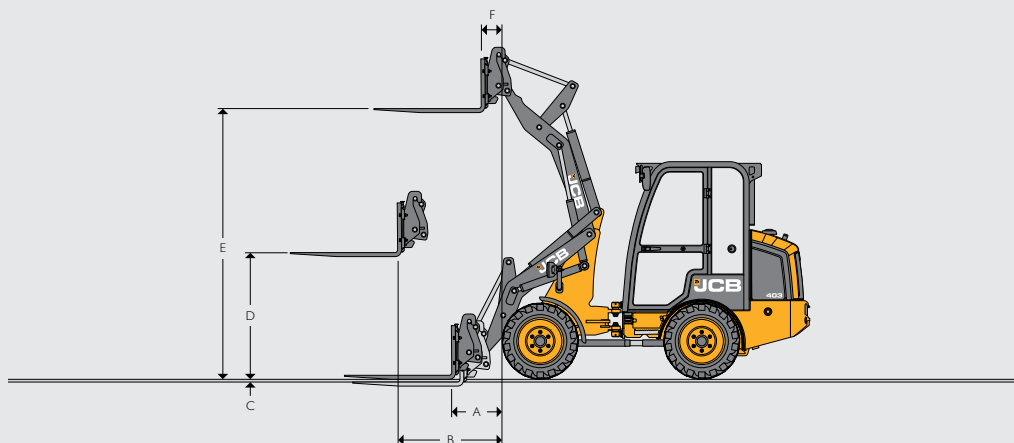

		Standard Arms	High Lift Arms	
	Fork carriage width	mm	1100	1100
	Length of tines	mm	1070	1070
A	Reach at ground level	mm	489	815
B	Reach at arms horizontal	mm	1029	1266
C	Top of tine above ground with arms down	mm	40	40
D	Arms, horizontal height	mm	1265	1265
E	Arms, max. height	mm	2702	2910
F	Reach at max. height	mm	199	311
	Tipping load straight*	kg	1213	1043
	Tipping load full turn (45°)*	kg	869	736
	Payload*	kg	695	589
	Attachment weight	kg	179	179
	Operating weight with canopy enclosure and wide industrial tyres (includes 75kg operator and full fuel tank)*	kg	2720	2734
	Weight for transport	kg	2645	2659

* At the centre of gravity distance 500mm. Based on 80% of FTTL as defined in ISO 14397-1:2007.

OPERATOR ENCLOSURE

Type	Operating weight kg	Standard Arms				High Lift Arms			
		Shovel		Forks		Shovel		Forks	
		STL kg	FTTL kg	STL kg	FTTL kg	STL kg	FTTL kg	STL kg	FTTL kg
Canopy/folding canopy	0	0	0	0	0	0	0	0	0
Cab	+90	+91	+76	+73	+61	+79	+66	+65	+55
Extra counterweight	+160	+190	+151	+149	+118	+165	+131	+132	+106

TYRE SIZE

Tyre size	Manufacturer	Type	Op weight kg	Standard Arms				High Lift Arms				Dimensions	
				Shovel		Forks		Shovel		Forks		Vertical mm	Width mm
				STL kg	FTTL kg	STL kg	FTTL kg	STL kg	FTTL kg	STL kg	FTTL kg		
31x15.50-15	BKT	Skidpower HD Wide Industrial Tyre	0	0	0	0	0	0	0	0	0	0	0
31x15.50-15	BKT	TR315 Wide Agricultural Tyre	-28	-30	-44	-22	-36	-25	-38	-21	-31	-2	+74
10/75-15.3	BKT	AS504 Agricultural Tyre (Narrow off-Set)	-68	-69	-79	-55	-64	-60	-68	-50	-56	-11	-250
10/75-15.3	BKT	AS504 Agricultural Tyre (Wide off-Set)	-68	-69	-79	-55	-64	-60	-68	-50	-56	-11	+2
10/75-15.3	BKT	MP567 Industrial Tyre (Narrow off-Set)	-60	-61	-72	-48	-58	-53	-62	-44	-51	0	-236
10/75-15.3	BKT	MP567 Industrial Tyre (Wide off-Set)	-60	-61	-72	-48	-58	-53	-62	-44	-51	0	+16

LOADER HYDRAULICS

Pump type		Gear
Pump I max. flow	l/min	40.5
Pump I max. pressure	bar	180
Max. auxiliary flow rate - single line	l/min	40.5
Max. auxiliary flow rate - second line	l/min	40.5
Hydraulic cycle times at engine revs		seconds
Arms raise (full bucket)		4.4
Bucket dump (full bucket)		2.7
Arms lower (empty bucket)		3
Total cycle		10.1

AXLES

Type	Standard
Make and model	ZF MT-L 3010 II (front), ZF MT-L 3010 II (rear).
Overall axle ratio	21.55 : 1
Chassis angle	degrees ± 6

All available with open differential or open differential with manual locking.

SERVICE FILL CAPACITIES

Hydraulic system	litres	40
Fuel tank	litres	48
Engine oil including filter	litres	6.7
Axle oil (front)	litres	3.2
Axle oil (rear)	litres	3.9
Engine coolant system	litres	6.5

ELECTRICAL OUTPUT

System voltage	volts	12
Alternator output	Ah	60
Battery capacity	Ah	72

NOISE AND VIBRATION

			Uncertainty	Measurement conditions.
Noise at the operator station	LpA	86 dB	+/- 1 dB	Determined in accordance with the test method defined in ISO 6396 and the dynamic test condition defined on 2000/14/EC.
Noise emission from the machine	LWA	101 dB	+/- 1 dB	Guaranteed equivalent sound power (external noise) determined in accordance with the dynamic test conditions defined in 2000/14/EC.
Whole body vibration	m/s ²	0.5	+/- 0.11 dB	ISO 2632-1:1997 normalised to an 8h reference period and based upon a test cycle comprising of loader work (soil).
Hand-arm vibration	m/s ²	2.5	N/A	ISO 5349-2:2001 dynamic test conditions.

EQUIPMENT

SERVICE AND MAINTENANCE

Grease gun	+
Wheel nut wrench	•
Engine air pre-cleaner	+

ELECTRICAL

Worklights front, reverse light rear	+
LED worklights (loader arm mounted)	+
LED worklights (x2 front, x1 rear, x1 rear reverse light)	+
Amber rotating beacon - 12V	+
Road lights	+
Number plate bracket with light	+

DRIVETRAIN

20kph transmission	•
30kph transmission	+
20kph transmission, manual diff-lock	+
30kph transmission, manual diff-lock	+
Varispeed (hand inching)	+

OPERATOR STATION

Canopy	•
Fully glazed cab	+
Canopy with front and rear screen (including wipers)	+
Foldable canopy	+
Left hand side gate	+
Heater/dimisting box (cab only)	•
Joystick auxiliary controls	+
12V in cab power socket	•
ROPS/FOPS safety structure	•
Interior light (cab only)	•
Front primary display dash	•
Two speed intermittent front windscreen wipe/wash and self-park (cab only)	•
Single speed rear windscreen wipe/wash and self-park (cab only)	•
Cup holder	•
Steering wheel spinner knob	•
Loader control isolator pin	•
Horn	•

STANDARD •

OPTIONAL +

FRONT PRIMARY DISPLAY

Warning lights	•
Direction indicators	•
High coolant temperature	•
Battery charging condition	•
Fuel gauge	•
Engine oil pressure	•
Hazard lamps	•
Park brake state	•
Road lights	•
Main beam lights	•
Engine pre-heat	•
Hi and low speed	•
Machine hours	•
Buzzer alerts	•
Operator presence	•

HYDRAULIC SYSTEM

Hydraulic quickhitch with in-cab isolation	•
Auxiliary hydraulic service	•
Secondary auxiliary hydraulic service	+
Front loader float	•
Indicator glass for hydraulic oil level	•
Hydraulic oil cooler	•
Free flow return line	+

EXTERNAL EQUIPMENT

Front fenders	•
Rear fenders (with wide tyres)	•
High lift loader arms	+
Belly guard protection plate	•
Recovery hitch	•
Lifting / tie down lugs	•
Articulation joint safety strut	•
Additional counterweight	+





ONE COMPANY, OVER 300 MACHINES.

Your nearest JCB dealer

WHEEL LOADER 403
 Max. engine power: 26kW (36hp)
 Operating weight cab: 2542kg, canopy: 2452kg Standard shovel capacity: 0.4m³

JCB Sales Limited, Rokester, Staffordshire, United Kingdom ST14 5JP.
 Tel: +44 (0)1889 590312 Email: salesinfo@jcb.com
 Download the very latest information on this product range at: www.jcb.com

©2009 JCB Sales. All rights reserved. No part of this publication may be reproduced, stored in a retrieval system, or transmitted in any form or by any other means, electronic, mechanical, photocopying or otherwise, without prior permission from JCB Sales. All references in this publication to operating weights, sizes, capacities and other performance measurements are provided for guidance only and may vary dependant upon the exact specification of machine. They should not therefore be relied upon in relation to suitability for a particular application. Guidance and advice should always be sought from your JCB Dealer. JCB reserves the right to change specifications without notice. Illustrations and specifications shown may include optional equipment and accessories. All images are correct at time of print. The JCB logo is a registered trademark of J C Bamford Excavators Ltd.

