

Quick Start Guide



Site Dumper
IT-2 High Tip



Disclaimer

- > This Quick Reference Guide is to provide quick and simple information to the Operator and does not include any health and safety aspects. In addition, because of our continual development of machines, features described in this Quick Reference Guide may differ from those on your machine. Nor errors and emissions be entirely ruled out.
- > This Quick Reference Guide **DOES NOT** replace the Operators Manual. You **MUST** read **ALL** the disclaimers and safety and other instructions in the Operators Manual before initially operating this product. Accordingly, no legal claims can be entertained on the basis of the data, illustrations or descriptions in this Quick Reference Guide.
- > This machine should be operated by any person who isn't appropriately qualified or had the appropriate training.
- > Operation of this machine without periodic maintenance could cause it to malfunction. For more information please contact your JCB Dealer.

Index

Intended use.....	4
Top 5 safety tips.....	5
Safety decals.....	7
Machine transport.....	9
Lifting points.....	10
Layout & controls.....	11
Start-up sequence.....	14
Drive inhibit system.....	15
Shutdown sequence.....	16
Maintenance position.....	17
Service/Maintenance.....	19
Access covers.....	22
Fluids & lubricants.....	23
Lubrication points.....	24
Tyre pressures & torque values.....	26
Dimensions.....	29
Troubleshooting / faqs.....	31

Intended use





General

- > Machine Type – Front Tip – High Tip
- > Self-propelled, seated operator, wheeled machine with an open body, which transports and dumps or spreads material
- > Steered through an articulating chassis, oscillating centre joint with an elevated high tipping skip function



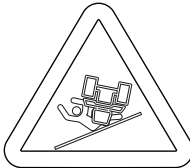
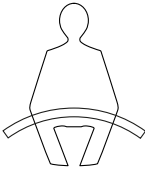
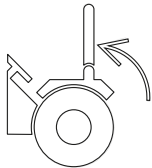

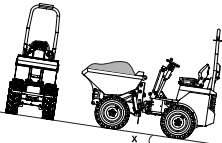
Intended Use

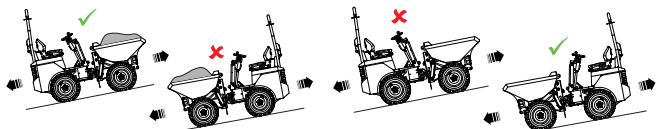
- > The machine is intended to be used in normal conditions for the applications and in the environmental condition as described in the operators manual
- > Essentially used for carrying free flowing materials from excavations or demolitions and general site building activities. Loading is performed by other machines or equipment
- > When used normally the machine transports and discharges various free flowing materials from its integral dumper body
- > The machine is not intended for use in mining and quarrying applications (other than for light yard cleaning operations), in demolition activities, forestry, any use underground, or in any kind of explosive atmosphere
- > If the machine is to be used in applications where there is a high silica concentration, risk due to materials containing asbestos or similar hazards, additional protective measures such as the use of PPE (Personal Protective Equipment) may be required
- > The machine should not be operated by any person who does not have an appropriate level of qualification, training or experience of use of this type of machine
- > Prior to use of the machine, its suitability (size, performance, specification etc.) should be considered with regards to the intended application and any relevant hazards that may exist

Top 5 safety tips

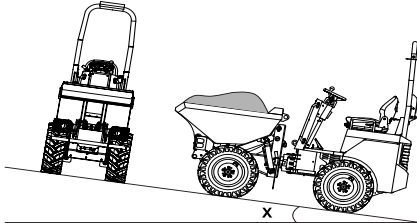
Activity/Risk	Advice
<p data-bbox="112 247 212 271">Overturn</p> 	<p data-bbox="356 247 1013 343">It is imperative that lap belts are worn at all times during operation with the ROPS frame in upright position. In the event of an overturn the operator should ensure hands remain braced on the steering wheel.</p>    <p data-bbox="356 574 957 670">In the event of an overturn do not start the engine or attempt to upright the machine as this can cause significant costly damage. Please contact the hirer or JCB dealer.</p> 
<p data-bbox="112 989 184 1013">Slopes</p> 	<p data-bbox="356 989 1024 1053">The maximum safe working angle is 18% (1 in 5 or 10.2°). This is referenced in the operator's manual and decal at the rear of the skip.</p>  <p data-bbox="356 1236 991 1300">The general rule on slopes should always be 'weight to the sky', the heavy end of the dumper should generally be uphill.</p> 

Top 5 safety tips

Activity/Risk	Advice
<p data-bbox="113 245 191 272">Driving</p> 	<p data-bbox="356 245 994 341">Ensure the dumper body is lowered during travel, particularly if driving on a slope. It is recommended to travel to a tipping point with the skip down before lifting/tipping.</p> 
<p data-bbox="113 649 210 676">Stopping</p> 	<p data-bbox="356 649 1028 778">Ensure the direction control stalk is left centrally in the neutral position with the park brake rocker switch engaged when the machine is not required to travel. Do not leave the machine parked on a slope/gradient over 25% (14 degrees).</p> 
<p data-bbox="113 1032 199 1059">Loading</p> 	<p data-bbox="356 1032 1023 1094">Do not load above the max fill line, parallel with the top of the skip. This could impede visibility and cause the machine to become unstable.</p>  <p data-bbox="356 1378 990 1441">The operator should dismount and stand clear of the machine while being loaded.</p>

Safety decals

Fig 1

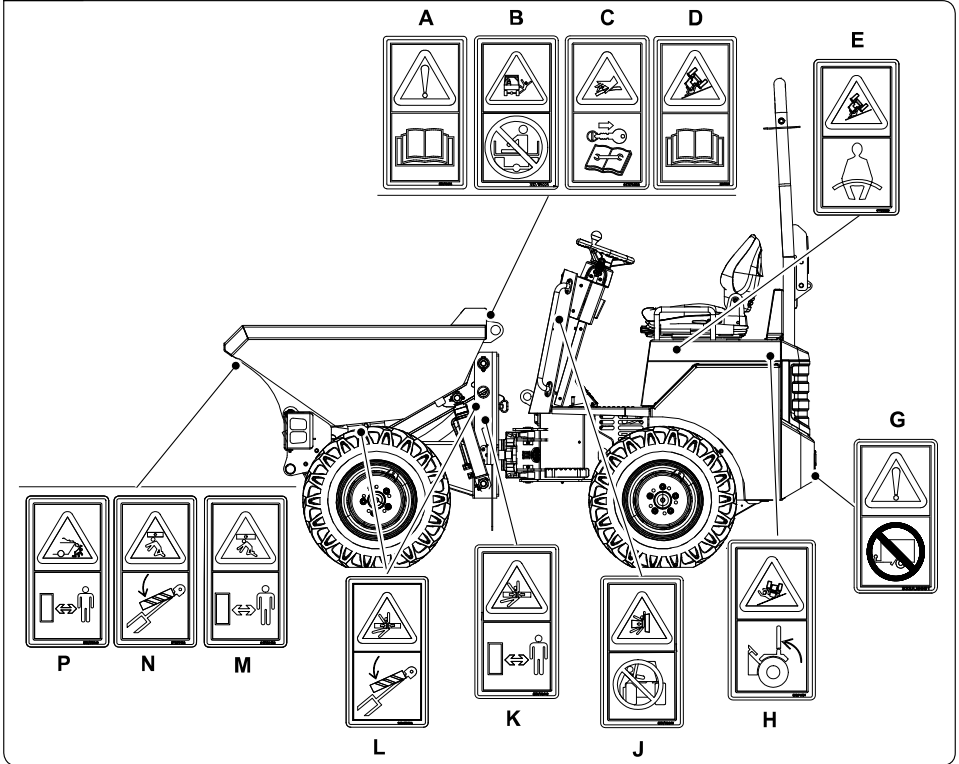

Fig 2

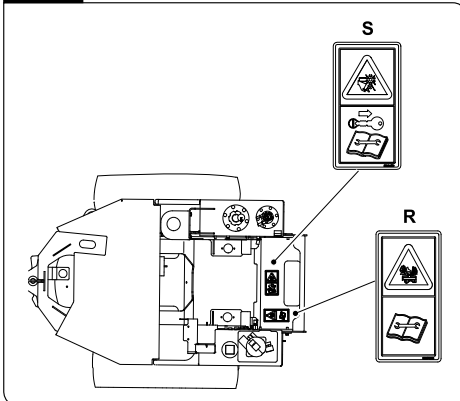
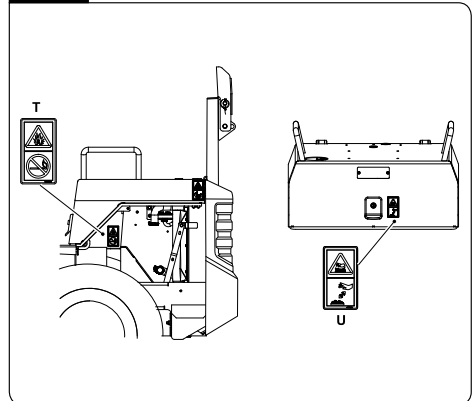

Fig 3



Safety decals

Item	Description
A	Warning. Read the Operator's Manual before you operate the machine.
B	Falling hazard. Do not ride in load bay.
C	Pressure hazard. Stop the engine, remove the starter key and consult the Service Manual before you complete any service or maintenance work.
D	Stability hazard. Ensure the load is within the capability of the machine. Read the Operator's Manual.
E	Warning. Crush hazard. Wear seat belt.
G	Warning. Trailer towing forbidden.
H	Warning. Crush hazard. Operate with the ROPS (Roll-Over Protective Structure) frame in the upright position where a risk of rollover exists.
J	Warning. Crushing of whole body. Do not operate the controls from outside of the machine.
K	Warning. Crushing of whole body. Keep a safe distance.
L	Crushing of whole body. Insert the articulated frame lock during maintenance and shipping.
M	Warning. Crushing of whole body. Keep a safe distance from machine.
N	Crushing of whole body. Insert the boom support device before you complete any service or maintenance work underneath the boom.
P	Crush hazard, falling material. Stay a safe distance from machine.
R	Warning. Hot fluid under pressure. Read the Operator's Manual.
S	Warning. Severing of hands and fingers. Keep clear of/do not reach into rotating parts. Read the Service Manual.
T	Explosion hazard. Remove sources of ignition.
U	Warning. Burns to fingers and hands. Stay a safe distance away.

Machine transport

Fig 4

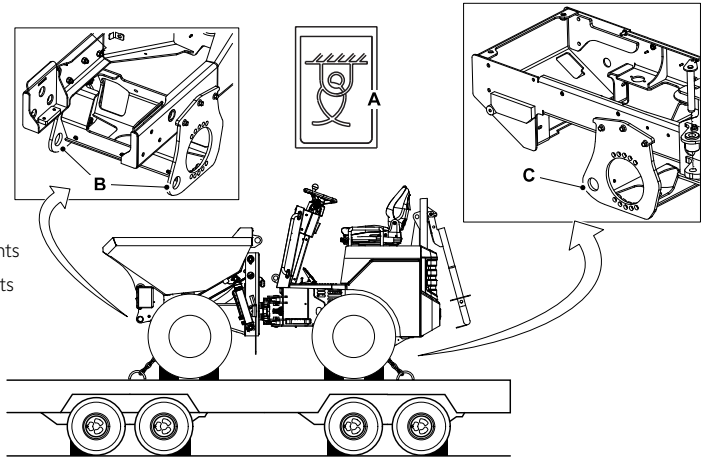

- A** Tie-down decal
- B** Front tie-down points
- C** Rear tie-down points

Fig 5

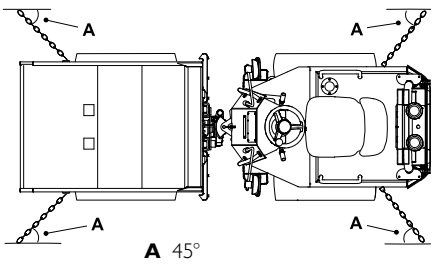

A 45°

Fig 6

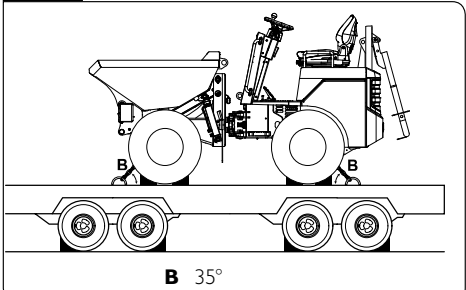

B 35°

Fig 7

- A** Locking pin and storage position
- B** Locking pin in installed position
- C** Locking hole
- D** Articulation joint

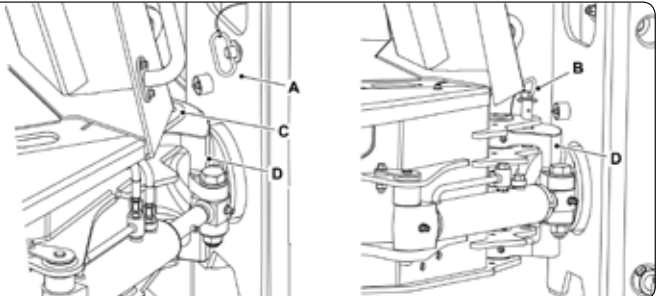

Lifting points

Fig 8

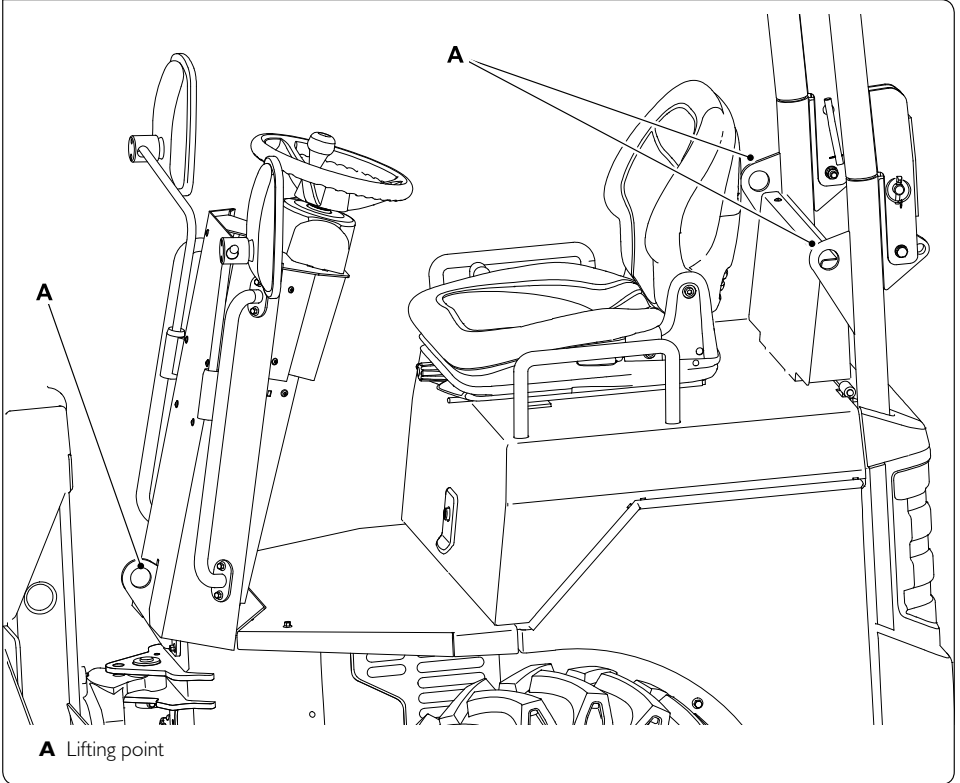

Lifting point decal

Layout & controls

Fig 9

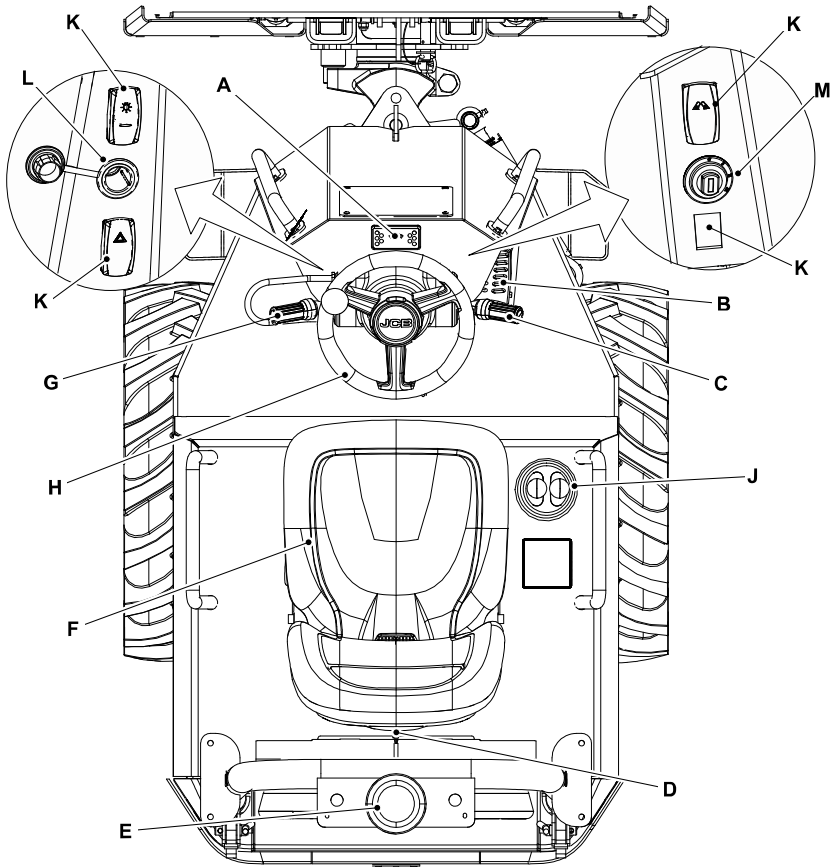

- | | |
|---|--|
| A Instrument panel | G Forward/park/reverse lever |
| B Accelerator pedal | H Steering wheel |
| C Multi-purpose stalk (inc. horn, indicator if fitted) | J Dumper body/skip operating levers |
| D Operator manual holder (rear of seat) | K Console switches |
| E Beacon(s) | L Power socket |
| F Operator seat | M Ignition switch |

Layout & controls

Fig 10

- A** Forwards – Left turn
 - B** Backwards – Right turn
 - C** Rotate – Headlights flash, high beam and low beam
 - D** Push – Horn
-
- 1** Headlights flash
 - 2** High beam
 - 3** Low beam

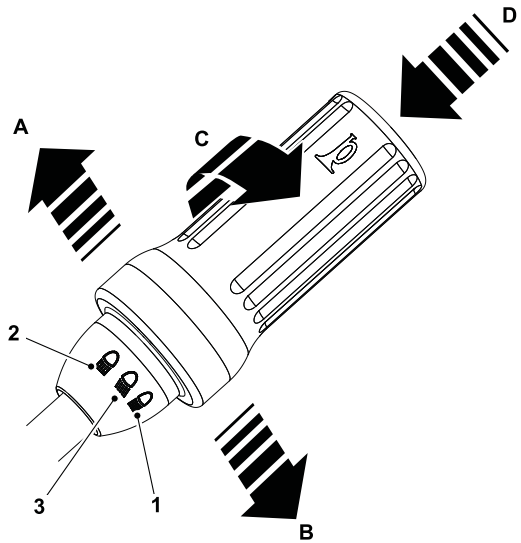
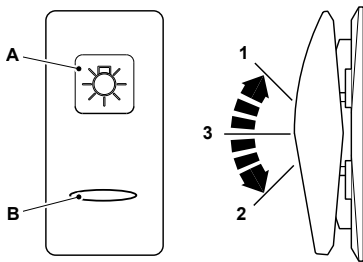
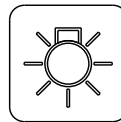

Fig 11



B Light bar

Fig 12



Road lights

- 1 = Off
- 2 = On (Sidelights and headlights)
- 3 = On (Sidelights only)



Hazard warning lights

- 1 = Off
- 2 = On (a light on the instrument panel flashes with the outside lights)

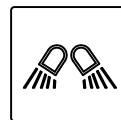

Work lights

- 1 = Off
- 2 = On

Layout & controls

Fig 13

- A** Battery charging condition
- B** Engine oil temperature
- C** Engine oils pressure
- D** Hydraulic oil temperature
- E** Engine pre-heat
- F** Main-beam lights
- G** Park brake
- H** Direction indicators
- J** Engine intake air filter
- K** Neutral
- L** Fuel level indicator
- M** Hour meter

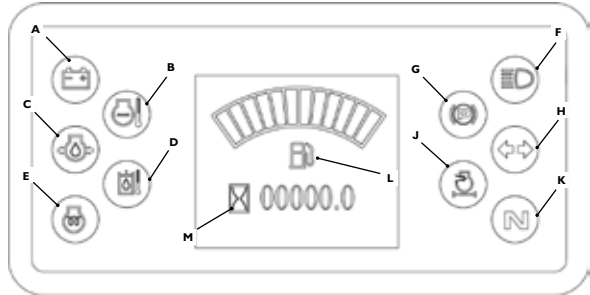

Fig 14

Push this pedal down to increase engine speed. Let the pedal up to reduce engine speed. With your foot off the pedal the engine will idle. When drive is selected push the pedal to increase travel speed. The machine brakes are hydraulically operated and applied automatically when you release the pedal.



Fig 15

- A** Raise dumper skip lever
- B** Tip dumper skip lever
- C** Pull
- D** Push

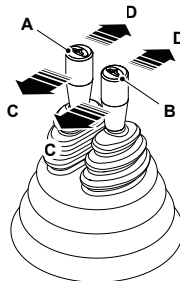

Start-up sequence

1 ROPS upright

Make sure the ROPS (Roll-Over Protective Structure) is in the upright position.



2 Battery isolator on

Make sure the battery isolator key is installed and switched on.



3 Fasten lap belt

The operator should be seated with the lap belt engaged.



4 Drive selection

Make sure the drive lever is in the neutral/park position.



5 Engine pre-heat

Turn and hold the ignition key to position 2 and wait for the pre-heat light to go off.



6 Machine start

Turn ignition key to position 3 to crank the engine.



7 Select forward drive/reverse

Set the drive lever to forward/ reverse position.



8 Accelerator pedal

Press the pedal to move the machine, depress to brake/stop the machine.



Drive inhibit system

To encourage operators to correctly engage lap belts during operation, JCB has developed a unique drive inhibit system fitted as standard on the IT-2 model.

This system ensures machine drive is only possible if the operator is sat in the seat and the lap belt is engaged, in this sequence. If the operator engages the lap belt first then sits on the seat, drive will not be enabled.

Please note: If the lap belt has not been securely engaged and the operator attempts to drive when sat on the seat, an intermittent audible alert will sound and machine drive will not be available. In this instance the operator needs to:

- 1 Engage the lap belt
- 2 Select neutral gear position
- 3 Engage forward or reverse travel

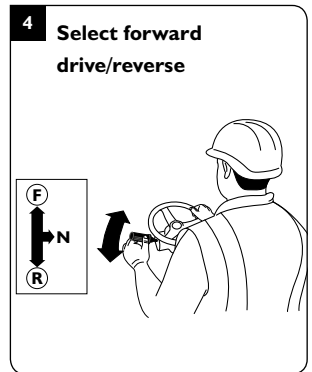
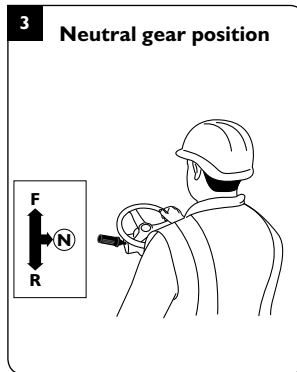
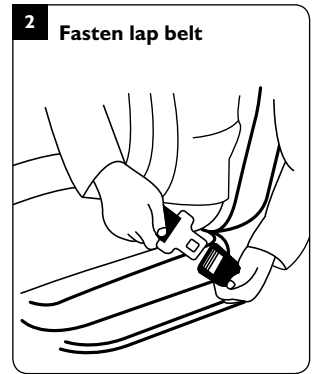
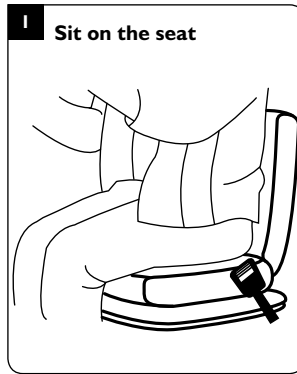

Shutdown sequence

1 Park machine up

Stop the machine on solid, level ground where the machine will not be a hazard.



2 Stop machine

Slowly release the pedal to bring the machine to a smooth stop.



3 Drive selection

Set the drive lever in the neutral/park position.



4 Switches off

If you are leaving the machine, make sure that all the switches are turned off.



5 Turn ignition off

Turn the ignition key to position 0 and remove the key.



6 Battery isolator

Turn the isolator key in a counter clockwise direction.



Maintenance position

Fig 16

Maintenance Position (Dumper Skip Lowered)

1. Park the machine on level solid ground.
2. Lower the dumper skip.
3. Stop the engine and remove the ignition key.
4. Disconnect the battery to prevent accidental operation of the engine.

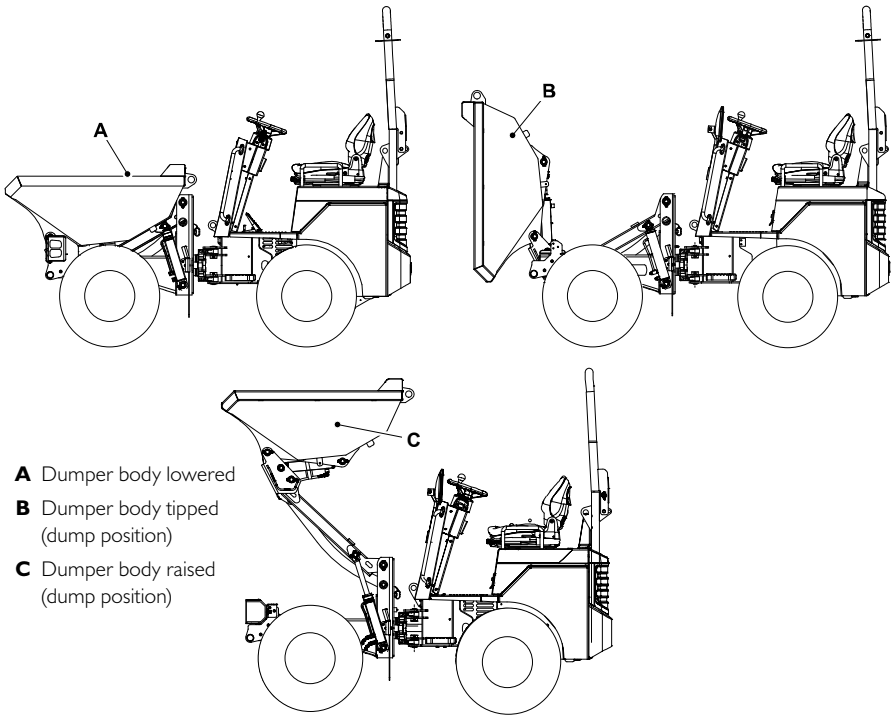

Maintenance position

Fig 17

Maintenance Position (Dumper Skip Tipped)

Installation of the safety strut

1. Fully tip the dumper skip.
2. Remove the maintenance strut from its stowage position and place over the piston rod of the ram.
3. Install the pin to the support and secure with the R clip.
4. Carefully lower the dumper skip until the weight is supported on the maintenance strut.

- A Maintenance strut – Stowage position
- B Pin
- C R clip
- D Maintenance strut – installed position

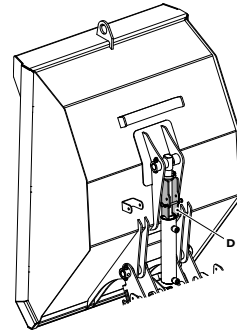
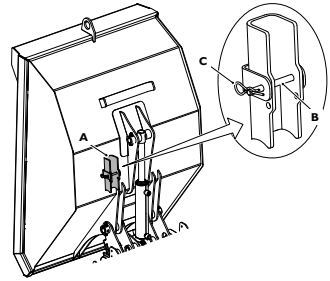

Fig 18

Maintenance Position (Dumper Skip Raised)

Installation of the safety strut

1. Fully raise the dumper skip.
2. Remove the maintenance strut from its stowage position and place over the piston rod of the ram.
3. Install the pin to the support and secure with the R clip.
4. Carefully lower the dumper skip until the weight is supported on the maintenance strut.

- A Maintenance strut – installed position

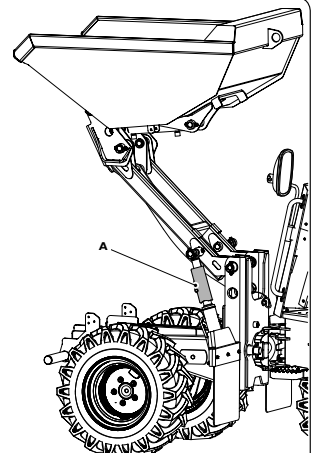

Service/Maintenance

Daily Checks	Action
Visually check machine for fluid leaks, damage, missing parts, unreadable safety labels etc.	Check (condition)
Operator platform and steps	Check (condition)
Articulation lock	Check (condition)
Dumper body maintenance strut	Check (condition)
ROPS (Roll-Over Protective Structure)	Check (condition)
Engine oil	Check (level)
Air filter blockage indicator warning light (instrument panel)	Check if illuminated
Fuel	Check (level)
Engine coolant - expansion tank (engine cold)	Check (level)
Hydraulic oil	Check (level)
Wheel nut security	Check (torque)
Tyre pressure	Check (condition)
Lights (warning lights and gauges)	Check (condition)
Seat and lap belts	Check (condition)
All electrical equipment	Check (operation)
Beacon(s)	Check (operation)

Weekly Checks	Action
Articulated joint	Lubricate
All other greasing point	Lubricate
Engine oil and filter	Replace
Air inlet/filter outer element	Clean
Fuel pipes and clamps bands	Check (condition/leaks)
Battery terminal	Check (condition)
Engine (excessive smoke, vibration, noise, overheating, performance, unusual smells)	Check (condition)
Operation all services	Check (condition)
Neutral start	Check (operation)
Park brake	Check (operation)
Start inhibit (system)	Check (operation)

Service Points – general

Fig I9

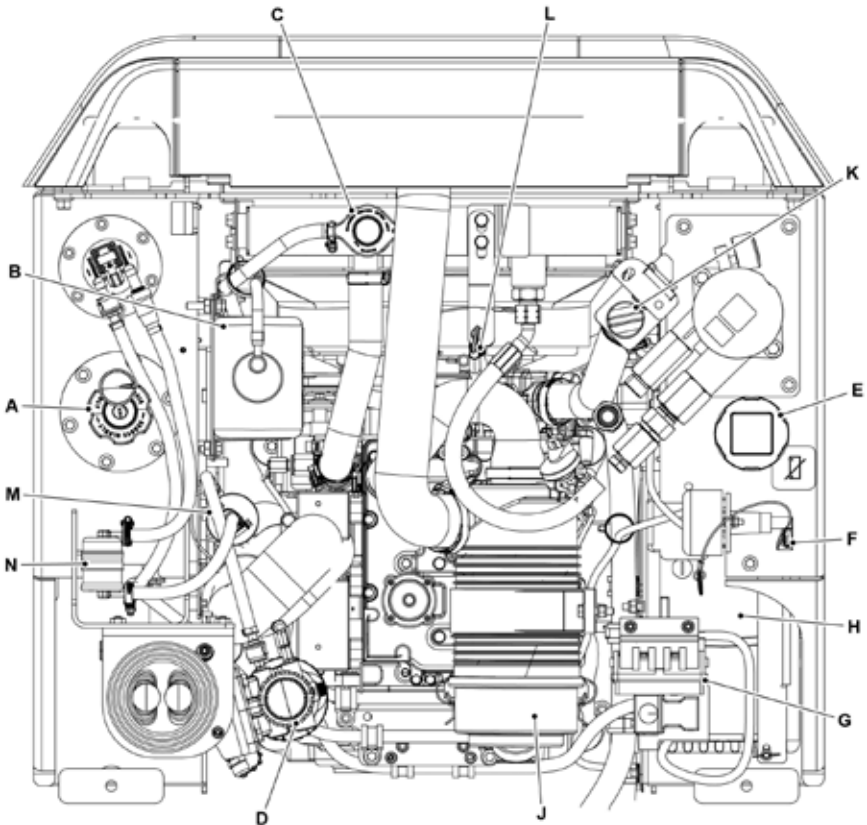

- | | |
|------------------------------------|------------------------------------|
| A Fuel tank filler cap | H Battery |
| B Coolant expansion bottle | J Air filter |
| C Radiator cap | K Engine oil filler cap |
| D Main fuel filter | L Engine oil dipstick |
| E Hydraulic tank filler cap | M Electrical fuel feed pump |
| F Battery isolator | N Fuel pre-filter |
| G Primary fuse box | |

Service Points

Fig 20

A Relays

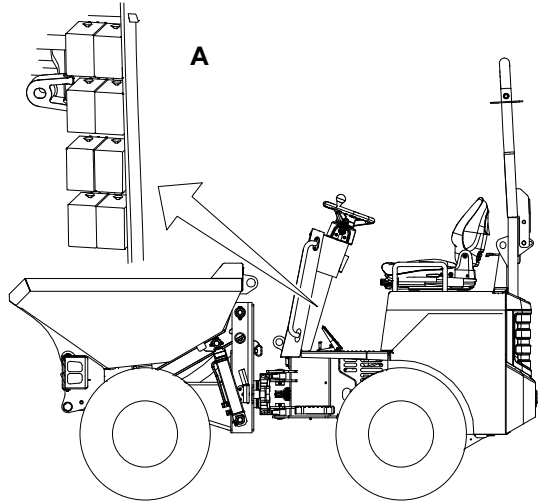
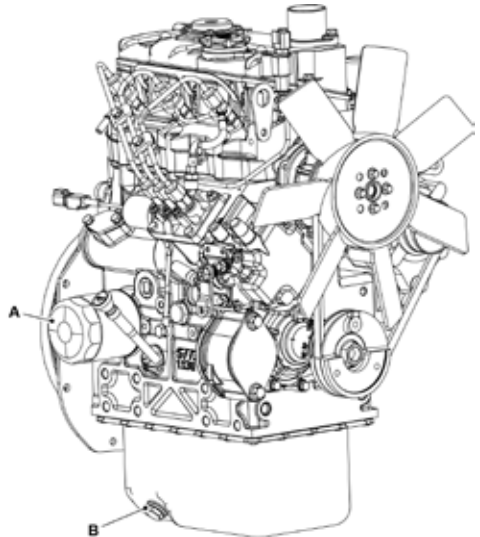

Fig 21

A Engine oil filter

B Drain plug



Access covers

Engine Access

Fig 22

- A Lock
- B Engine compartment cover

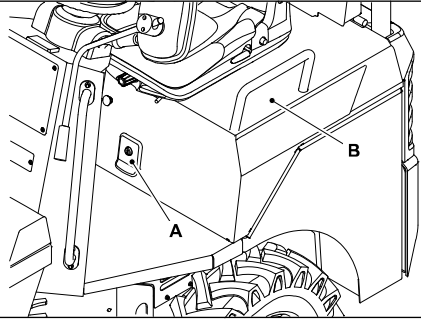

Transmission Access

Fig 23

- A Floor plate
- B Floor plate bolts

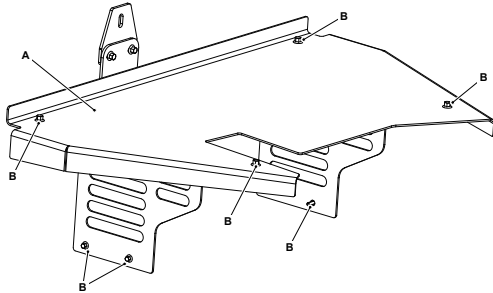

Hydraulic Oil

Fig 24

- A Inspection window
- B Hydraulic tank filler cap

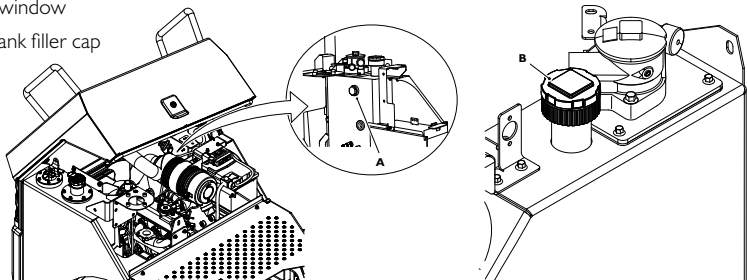

Fluids & lubrication

General

Notice: No warranty liability will be accepted for engine failures where unacceptable fuel grades (or their equivalent) have been used at any stage.

Item	Capacity	Fluid / Lubricant	JCB Part Number	Container Size*	Specification
Fuel tank	30L	Diesel	-	-	Refer to 'Fuel'
Engine (oil)	4.4L (max) 3.4L (min)	JCB Engine Oil EP 15W40	4001/1805	20L	ACEA ES/B3/A3, API CH-4/SJ
Engine coolant	3.4L	JCB Antifreeze HP/Coolant	4006 / 1120	20L	ASTM D6210
Hydraulic fluid (including motors)	28L	JCB Hydraulic Fluid OP46	4002 / 2005	20L	
Grease points	As required	JCB Special HP Grease	4003 / 2017	0.4kg	

* For information about the different container sizes that are available (and their part numbers), please contact your JCB dealer.

JCB part numbers are liable to change and may also vary by region. For the latest information, always check with your dealer/distributor.

Lubrication points

Steering Ram

Fig 25

A Grease nipple

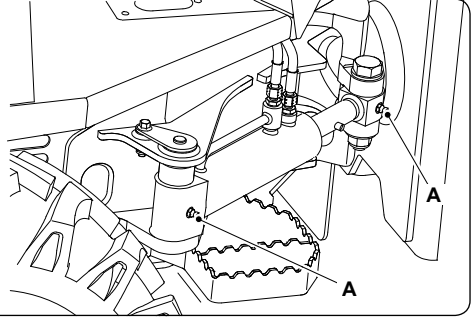

Dumper Skip Lift Arm Ram

Fig 26

A Grease nipple

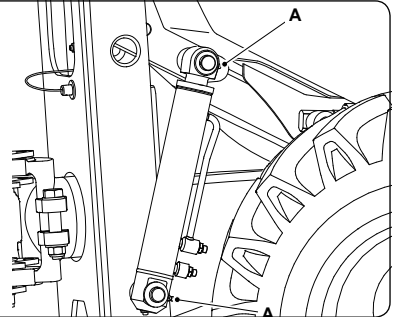

Dumper Skip Ram

Fig 27

A Grease nipple

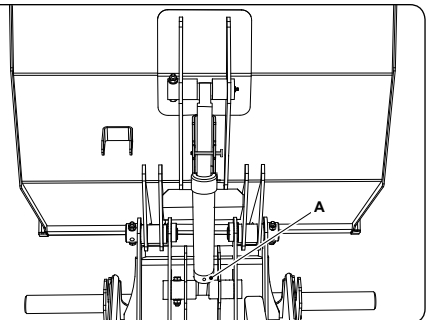

Lubrication points

Pivot Pins – Dumper Skip Lift Arm and Carriage Pivots

Fig 28

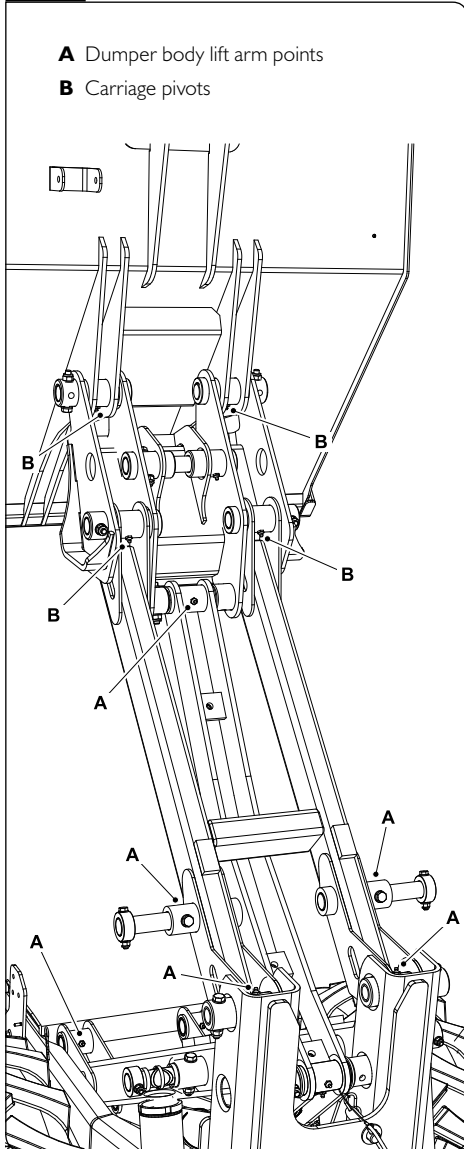

Pivot Pins – Dumper Skip Ram Pivot

Fig 29

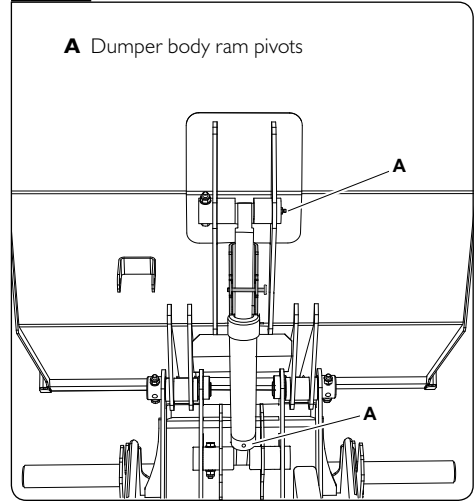

Articulated Joint

Fig 30

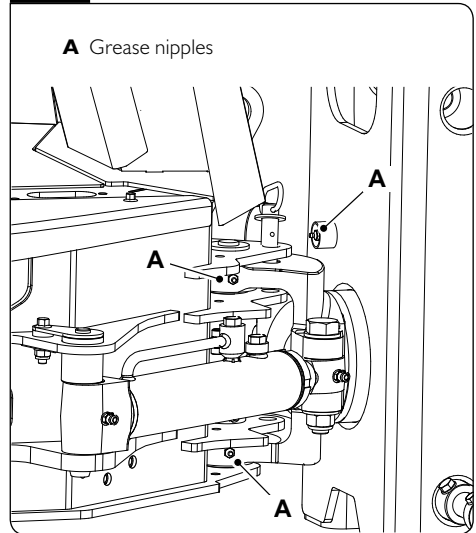

Tyre pressures & torque values

Tyre pressures

Make	Size	Pressure – front tyre	Pressure – rear tyre
Starco	255/75x15.3 8PR AS Dumper	2.3 bar (33psi)	1.4 bar (20psi)
Starco (narrow option)	7.00 x 12 – 6PR	3.2 bar (46psi)	2.6 bar (38psi)

Torque values

Component	Torque
Front and rear wheel nuts	250N-m
ROPS (Roll-Over Protection Structure) mounting bolts	116N-m
ROPS hinge bolts	Tighten to remove the gap
Engine oil drain bolt	40-45N-m

Dimensions

Fig 31

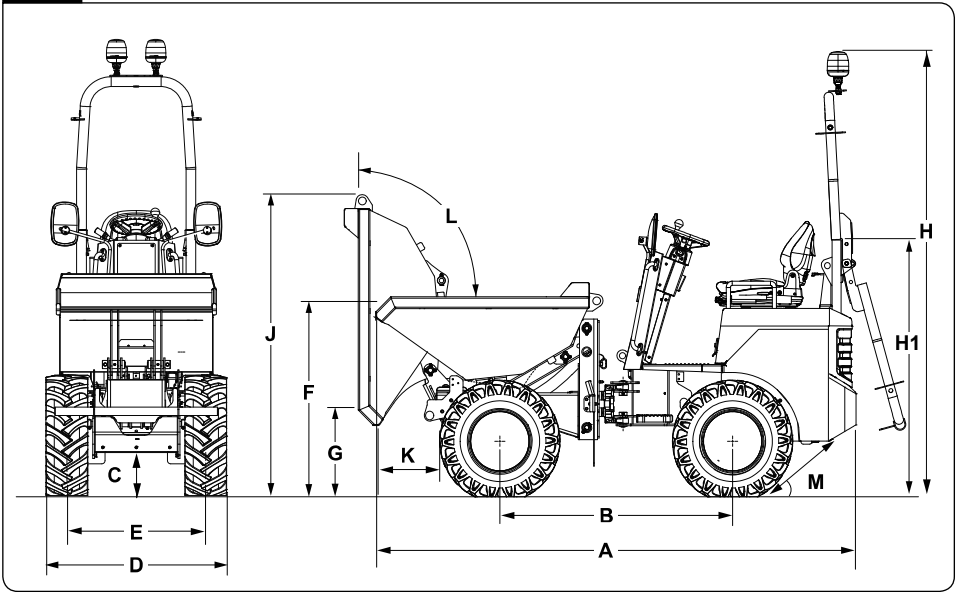
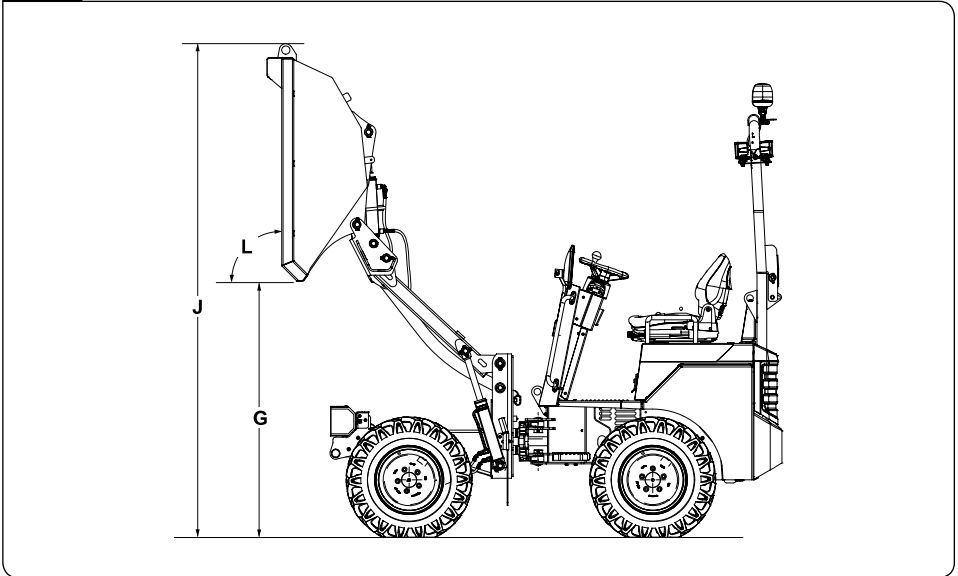
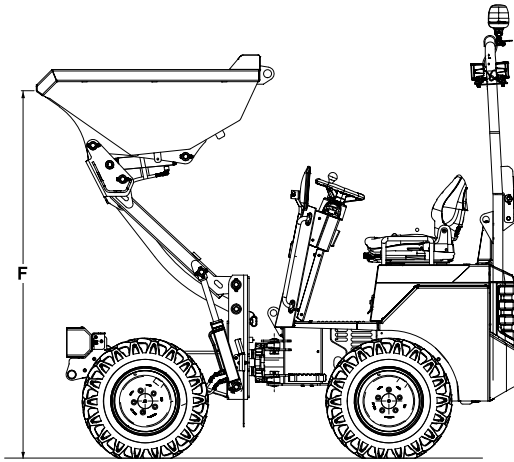

Fig 32



Dimensions

Fig 33



Item	Description		Machine with standard tyres	Machine with narrow tyres
A	Overall length	mm	3,095	3,095
B	Wheelbase	mm	1,500	1,500
C	Minimum ground clearance	mm	263	225
D	Width over tyres	mm	1,106	980
E	Track width	mm	850	782
F	Height to front lip of dumper body – untipped (lowered/raised)	mm	1,134/2,259	1,096/2,221
G	Height to front lip of dumper body – tipped (lowered/raised)	mm	452/1,573	414/1,535
H	Height to top of ROPS (raised, with/without beacon)	mm	2,792/2,602	2,754/2,564
HI	Height to top of ROPS (folded)	mm	1,624	1,586
J	Dump height (untipped/tipped)	mm	1,865/3,037	1,827/2,999
K	Discharge distance front (lowered/raised)	mm	391/263	436/308
L	Dumper body tip angle	degrees	90	90
M	Departure angle	degrees	36	33

Standard tyres = 255/75-15.3 (8 ply)

Narrow tyres = 7.00 x12 (6 ply)

Dimensions

Fig 34

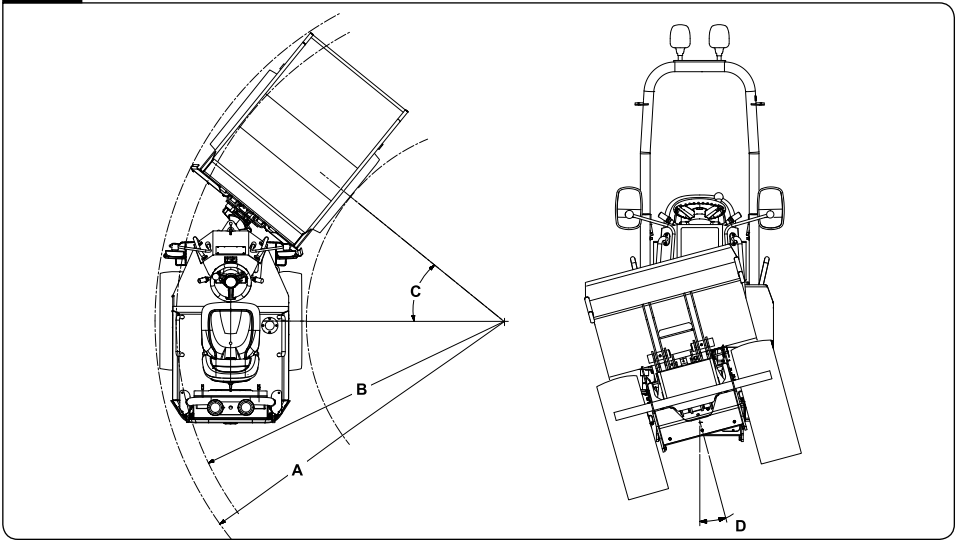

Turning circle

Item	Description		Length	
			Standard tyres	Narrow tyres
A	Turning circle of dumper body (radius)	mm	2,712	2,713
B	Turning circle of tyres (radius)	mm	2,559	2,524
C	Steering angle	degrees	39	39
D	Body oscillation angle	degrees	15	15

Weights

Description		
Total weight unladen with full fuel tank and oils [†]	kg	1,515
Total weight unladen full of fuel and oils	kg	1,440

[†] According to ISO6016 – unladen machine plus full fuel tank and 75kg operator

Dumper body capacity

Maximum safe payload	Heaped capacity	Water capacity	Struck capacity
1,000kg	0.54m ³	0.31m ³	0.44m ³

Dimensions

Driving performance

Speed in gears (unladen)

Gear	Speed	
	Standard tyres	Narrow tyres
I	11.9kp/h (7.4mph)	10.5kp/h (6.5mph)

Maximum operating slope

	Standard tyres		Narrow tyres	
	Percentage slope	Degree	Percentage slope	Degree
iHT	18	10.2	17	9.8

Noise data

Engine rating [‡]	LpA	LwA
16.1kW	79	101

[‡] Gross power per ISO 3046.

Troubleshooting/FAQs

Issue / FAQ	Resolution/Answer
<p>The machine will not start.</p>	<p>Ensure the start up sequence has been followed (page 14).</p> <p>Please check the following:</p> <ul style="list-style-type: none"> • Battery isolator switch is engaged • Operator needs to be seated (presence switch) • Drive selector is in the central location for neutral gear / park • Engine Pre-Heat function – cold-start aid. Turn and hold the ignition key in position II and wait for the pre-heat light to go off. Note: it is recommended to hold the pre-heat function for 10 seconds in cold conditions (even if the light is not illuminated) • Fuel level • Battery charge <p>If the machine still will not start please contact the hirer/JCB dealer.</p>
<p>The machine has overturned, after the machine has been lifted to an upright position can the engine be started?</p>	<p>ABSOLUTELY NOT! Starting an engine following a machine overturn can result in significant damage and replacement/repair cost. Please contact the hirer/JCB dealer in the event of this taking place.</p>
<p>The green LED beacon (if fitted) does not inhibit engine start.</p>	<p>The green LED beacon option indicates that the lap belt is engaged into the buckle. Engine start inhibit is linked to the Drive Inhibit System only</p>
<p>What is the rated towing capacity?</p>	<p>The dumper is not fitted with a tow hitch. The dumper is fitted with a recovery hitch, for occasional recovery use only.</p>



JCB Sales Limited, Rokeceter, Staffordshire, United Kingdom ST14 5JP Tel: +44 1889 590312 Email: salesinfo@jcb.com

Download the very latest information on this product range at: www.jcb.com

All rights reserved. No part of this publication may be reproduced, stored in a retrieval system, or transmitted in any form or by any other means, electronic, mechanical, photocopying or otherwise, without prior permission from JCB Sales. All references in this publication to operating weights, sizes, capacities and other performance measurements are provided for guidance only and may vary dependant upon the exact specification of the machine. They should not therefore be relied upon in relation to suitability for a particular application.

Guidance and advice should always be sought from your JCB Dealer*. JCB reserves the right to change specifications without notice. Illustrations and specifications shown may include optional equipment and accessories.