

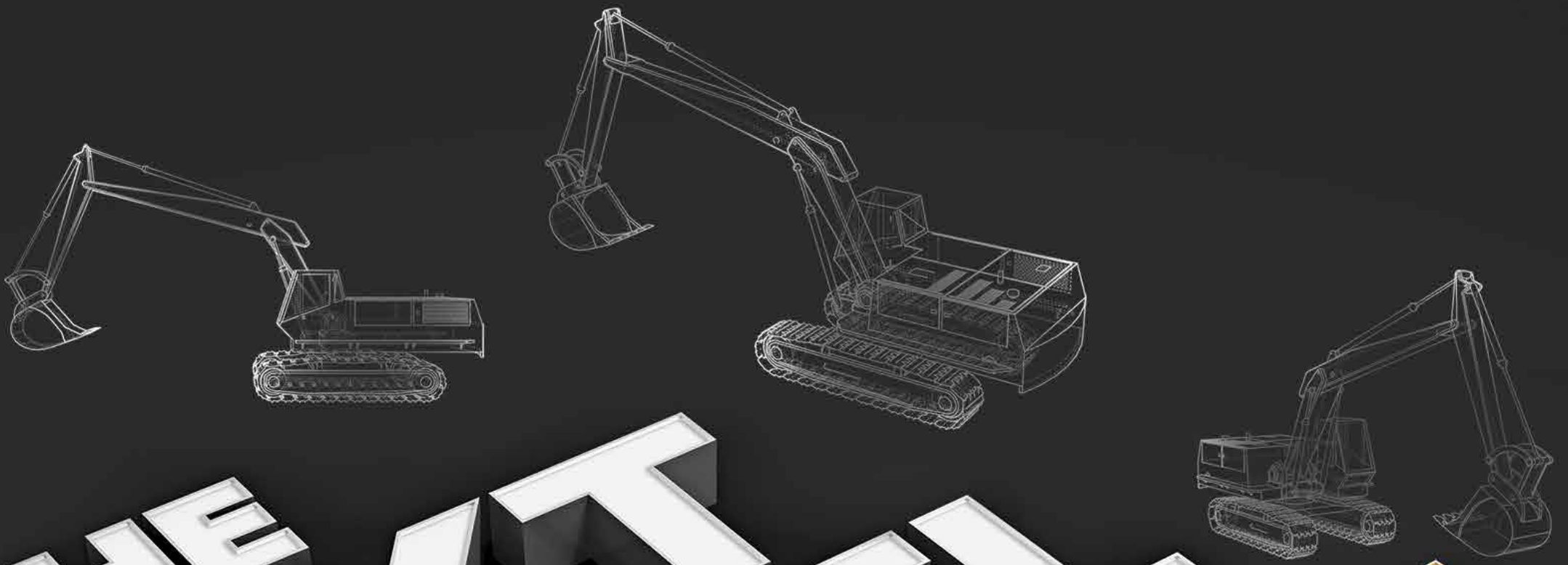

Always looking
for a better way



**MOVE TO
THE NXT LEVEL**



**THE
NXT
LEVEL
OF EXCAVATION**

JCB presents the NXT series of Tracked Excavators, Powered by **IntelliControl** - The JCB NXT series is packed with technology to take your business to the NXT level, IntelliControl is a new intelligent way to offer excellent fuel efficiency and productivity.

The JCB NXT series comes with an advanced telematics system - JCB LiveLink, which is CAN based technology that keeps you connected for total control.

Backed by industry's finest customer support network, always look for a better way with JCB.

Take your business to **THE NXT LEVEL**, with the new series of JCB Tracked Excavators.



MOVE TO THE NXT LEVEL



**NO FAULT
FORWARD**



MOVE TO THE NXT LEVEL

NXT LEVEL OF RELIABILITY

RELIABLE AND ROBUST COMPONENTS FOR TOUGH JOBS

**Deep section boom design & cast pivot ends.
Strengthened foot box and cylinder pivot section.**

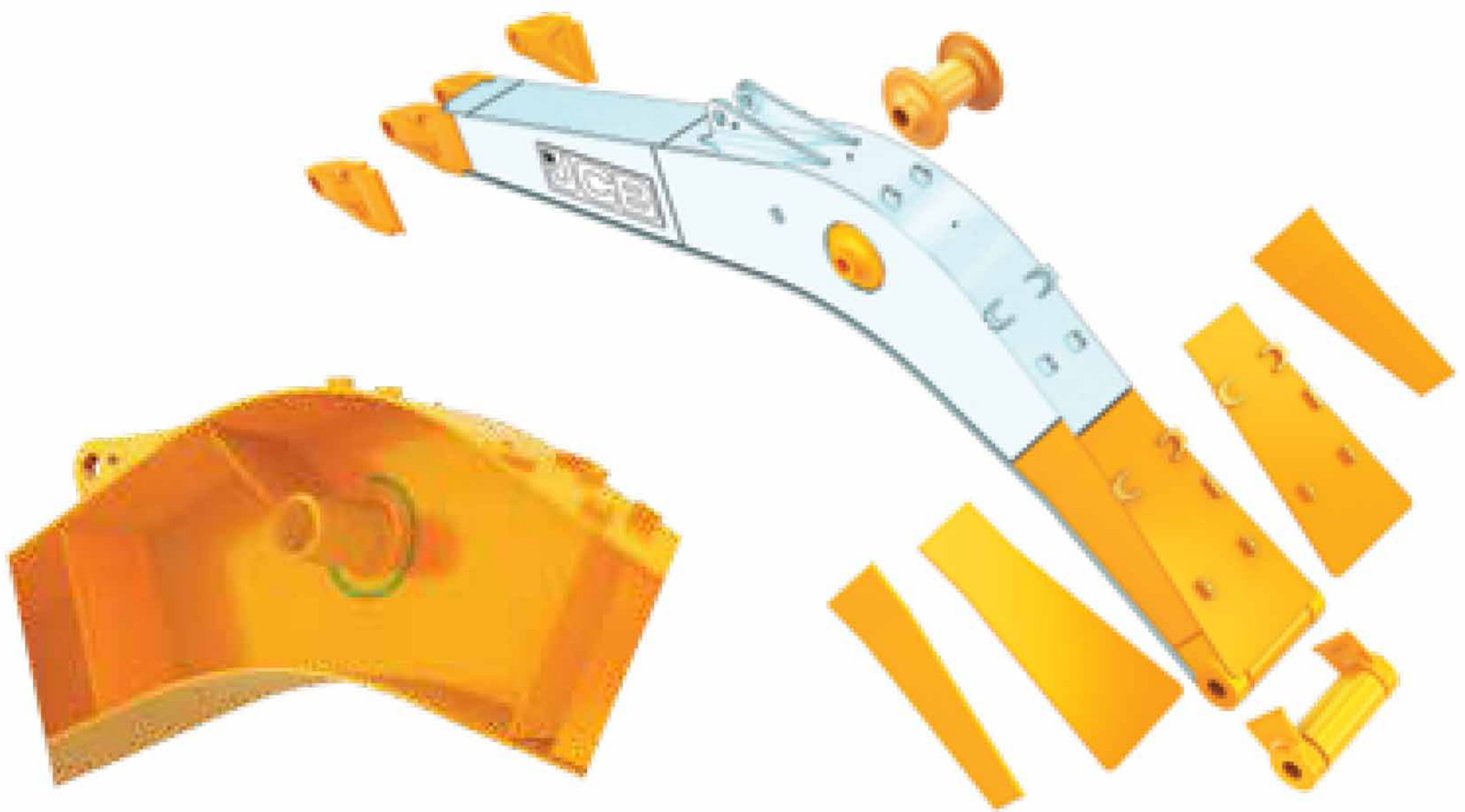

Available in JCB NXT205 & JCB NXT215LC Models.

MOVE TO THE NXT LEVEL

Reinforced arm with additional full length strengthening plate.

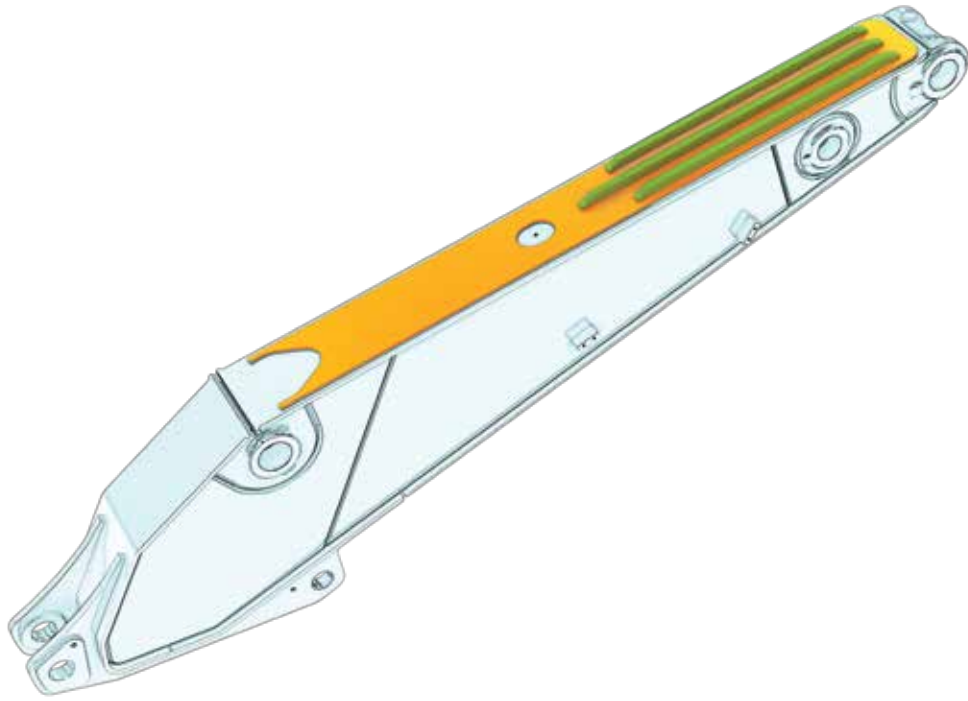

Proven hydraulic components & upgraded filtration system

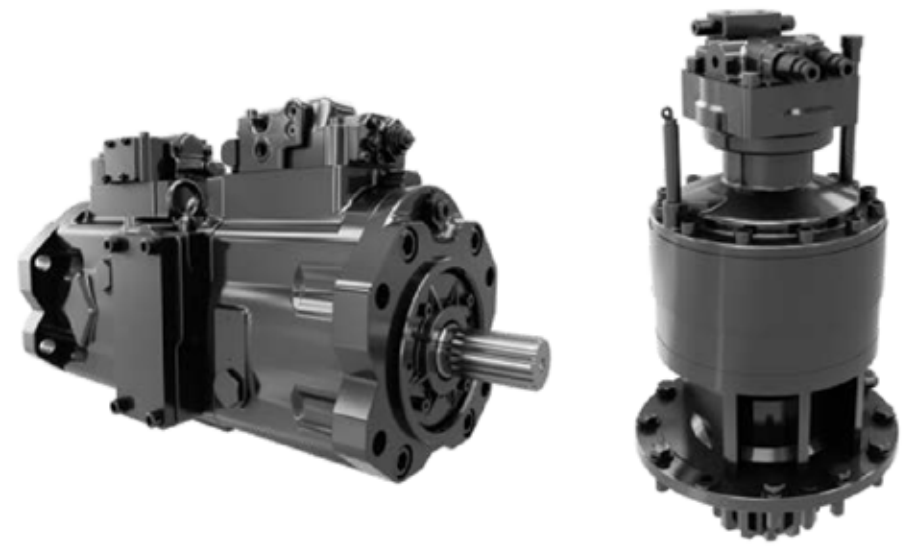

Heavy duty undercarriage reducing the maintenance cost.



Strengthened X-frame



Heavy duty upper frame

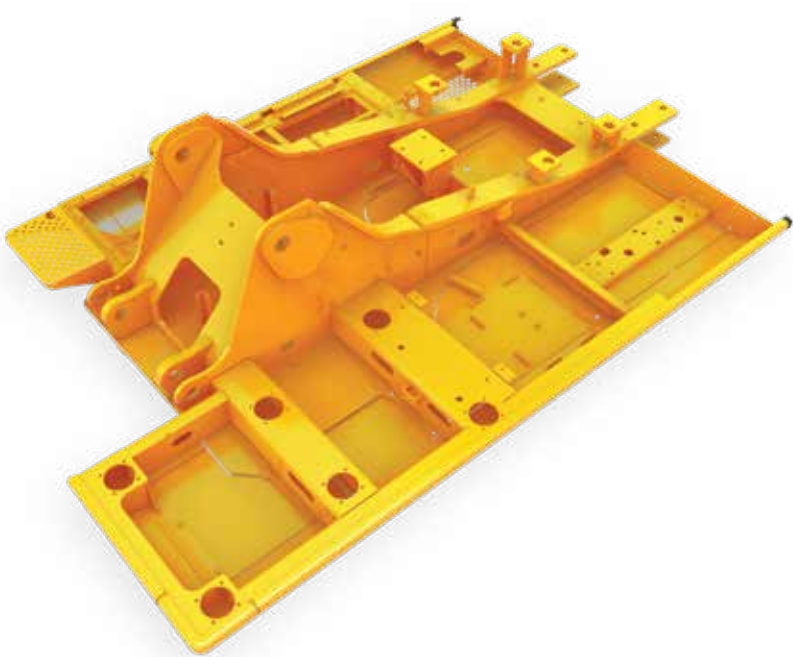

Heavy-duty bucket with hard facing



MOVE TO THE NXT LEVEL

NXT LEVEL OF INTELLIGENCE

DIGITAL ANTI-GLARE
INFORMATIVE COLOUR
DISPLAY

INTELLI
CONTROL

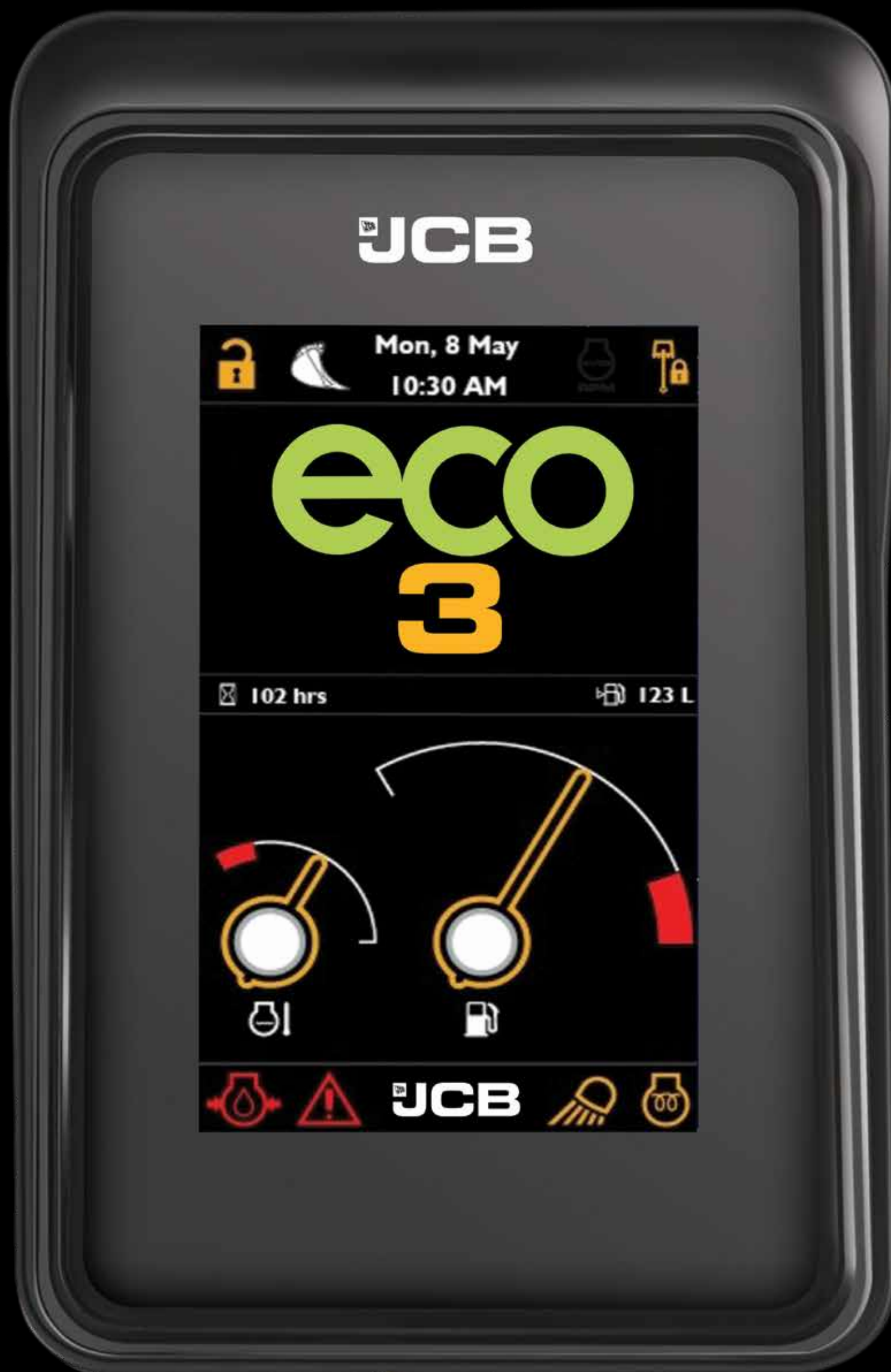

MOVE TO THE NXT LEVEL

10 Modes offer
class-leading fuel efficiency

eco
1

eco
2

eco
3

eco
4

eco
5

eco
6

eco
7

eco
8

Power
9

Power⁺
10



**Monitoring machine operation,
maintenance and safety.**



**Integrated CAN based advanced
telematics system - JCB LiveLink.**

MOVE TO THE NXT LEVEL

NXT LEVEL OF FUEL EFFICIENCY



JCB

DYNAMIC

EFFICIENCY 

*T&C Apply.

In JCB NXT205 & JCB NXT215LC Models.

MOVE TO THE NXT LEVEL

JCB **ecoHydraulics** minimises energy losses to enhance fuel efficiency.



Regenerative hydraulic system

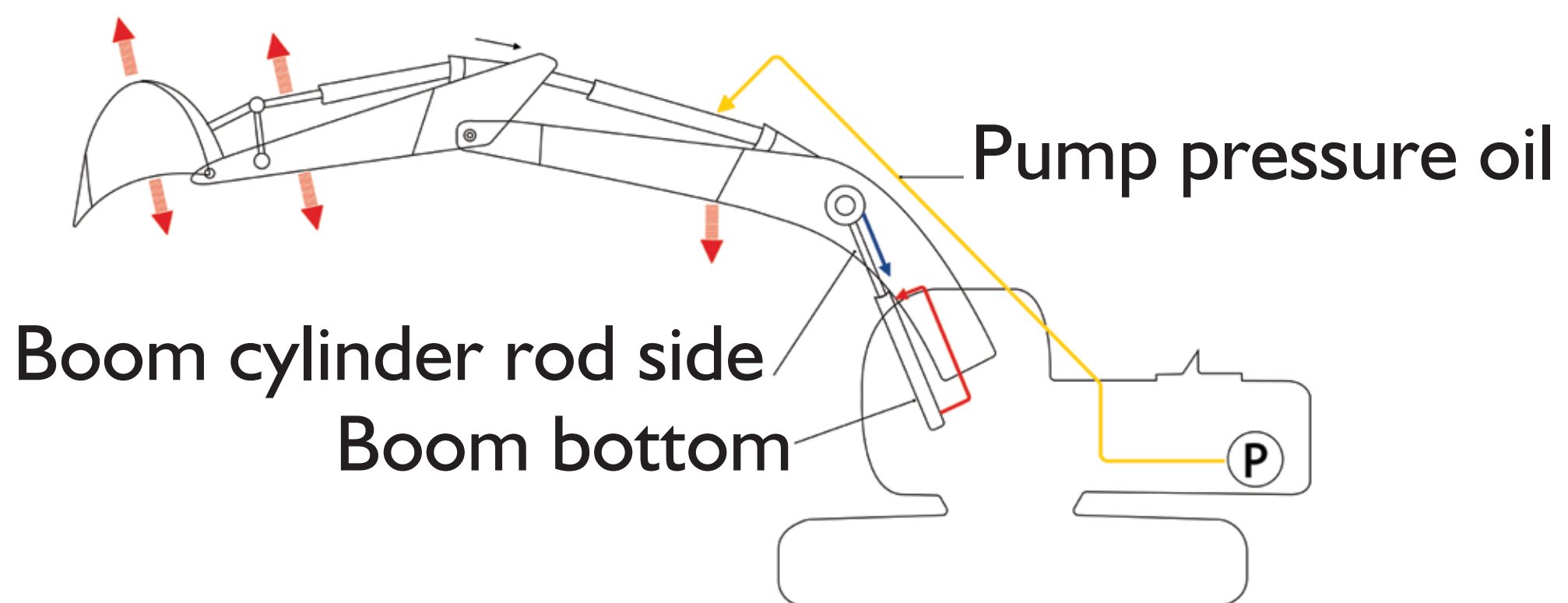

Hydraulic regeneration system for faster operations and fuel savings



*Results shown are based on internal trials done in standard test conditions. It may vary on basis of operator efficiency and type of application.

MOVE TO THE NXT LEVEL

NXT LEVEL OF EASE OF USE

LARGE & MULTI-COLOURED DISPLAY INFORMATION FOR EASY UNDERSTANDING.



Rotary switch controls



Display of fuel quantity (Litre)



Rock-breaker over use alerts



Rear view camera option

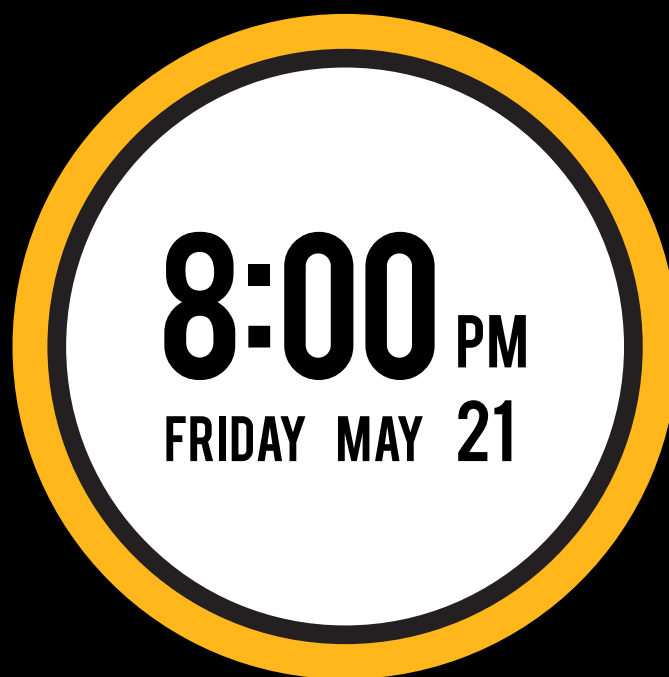

Date & time display

MOVE TO THE NXT LEVEL

EASE OF MAINTENANCE

HIGH SERVICE INTERVALS	
Hydraulic main filter	Every 1,000 hours
Hydraulic oil	Every 5,000 hours



Service due information

MOVE TO THE NXT LEVEL



Advanced self diagnosis system for pro-active maintenance



Display of all critical parameters for easy health monitoring

Display of operating parameters



Breaker hours



Battery voltage

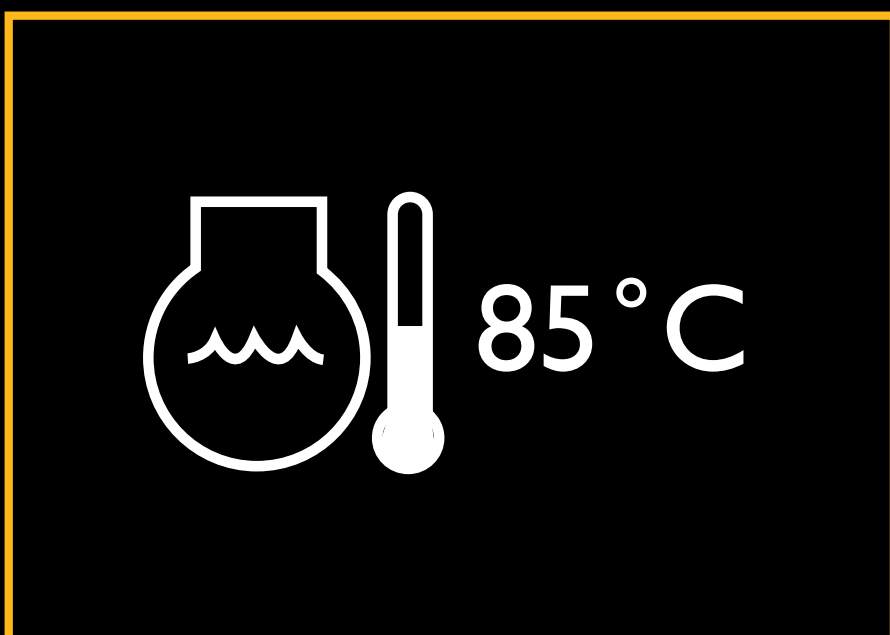

Engine Temperature

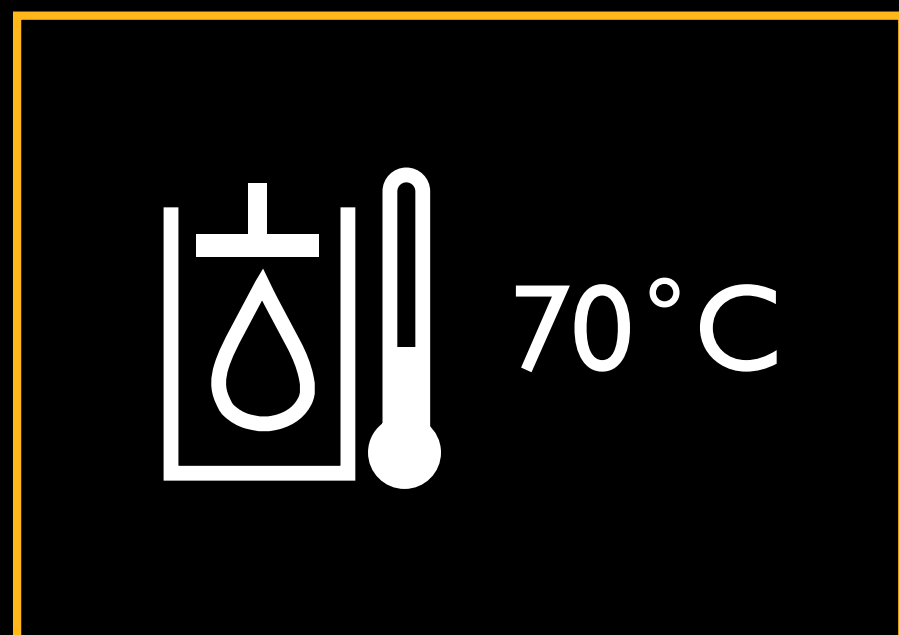

Hydraulic Temperature

MOVE TO THE NXT LEVEL

EASE OF SERVICE



MOVE TO THE NXT LEVEL



**Easy Trouble Shooting,
without laptop**



**Critical
health alerts**



**Service
due reminder**

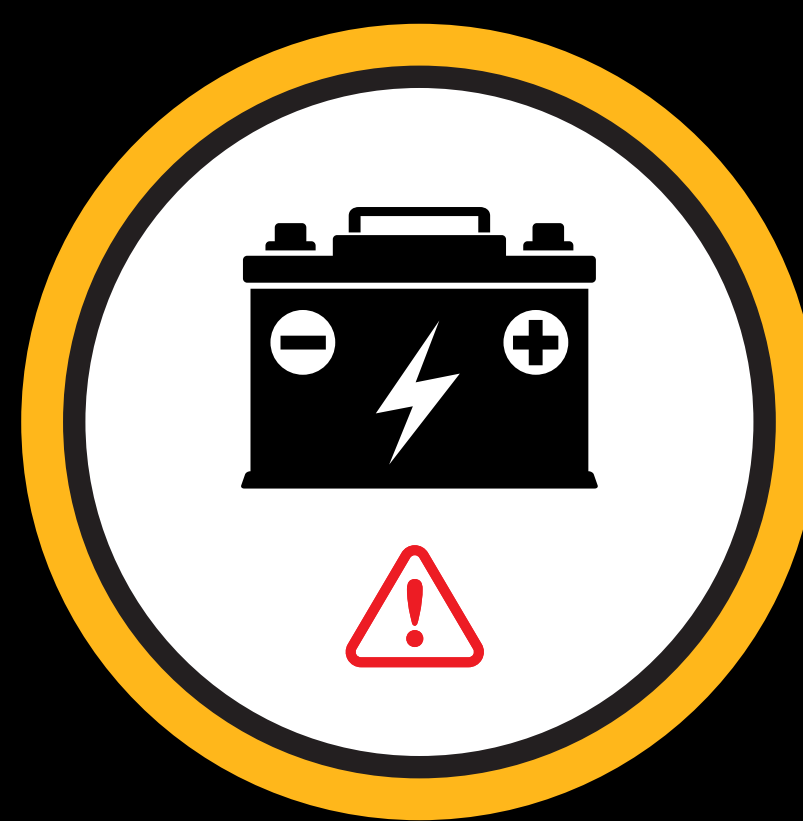

**Battery disconnect
switch**

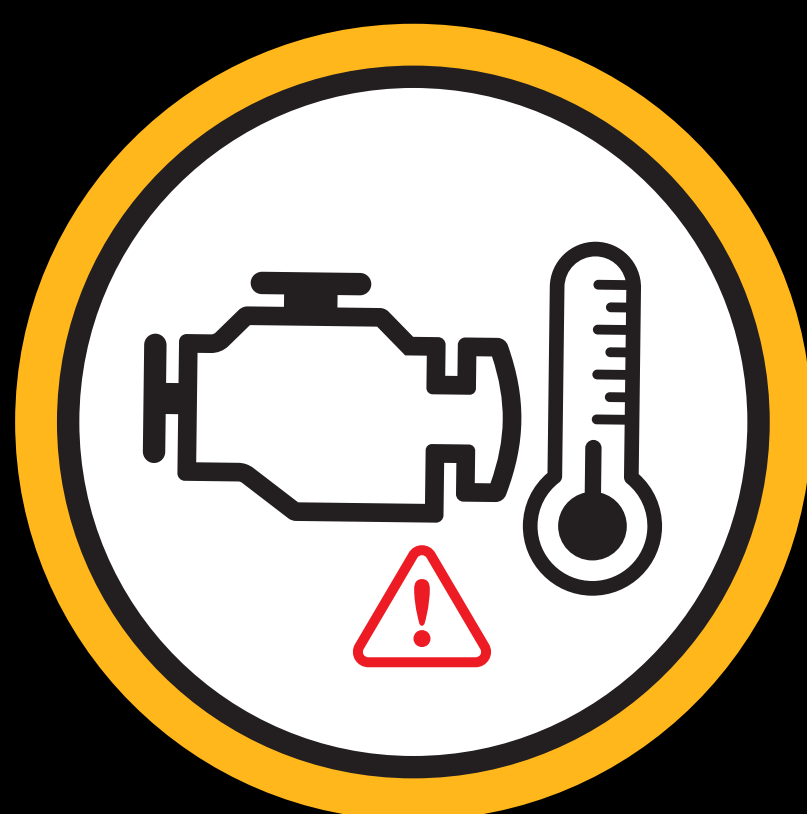

**Engine
Temperature**

MOVE TO THE NXT LEVEL

SUPPORTED BY SKILLED EXCAVATOR ENGINEERS TRAINED BY JCB



**JCB trained and
certified engineers**



**Best-in-class
service and repairs**



**On-site customer
training and support**



MOVE TO THE NXT LEVEL

NXT LEVEL OF MACHINE SAFETY

ENGINE & HYDRAULIC OVERHEAT SAFETY SYSTEM



**ENG TEMP
HIGH**

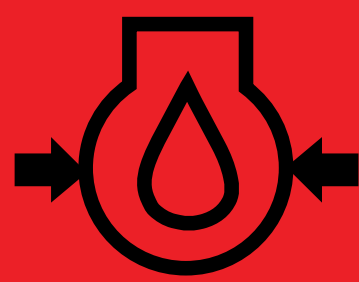

**ENG OIL
PRESS LOW**

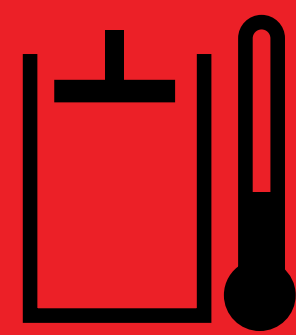

**HYD OIL
TEMP HIGH**

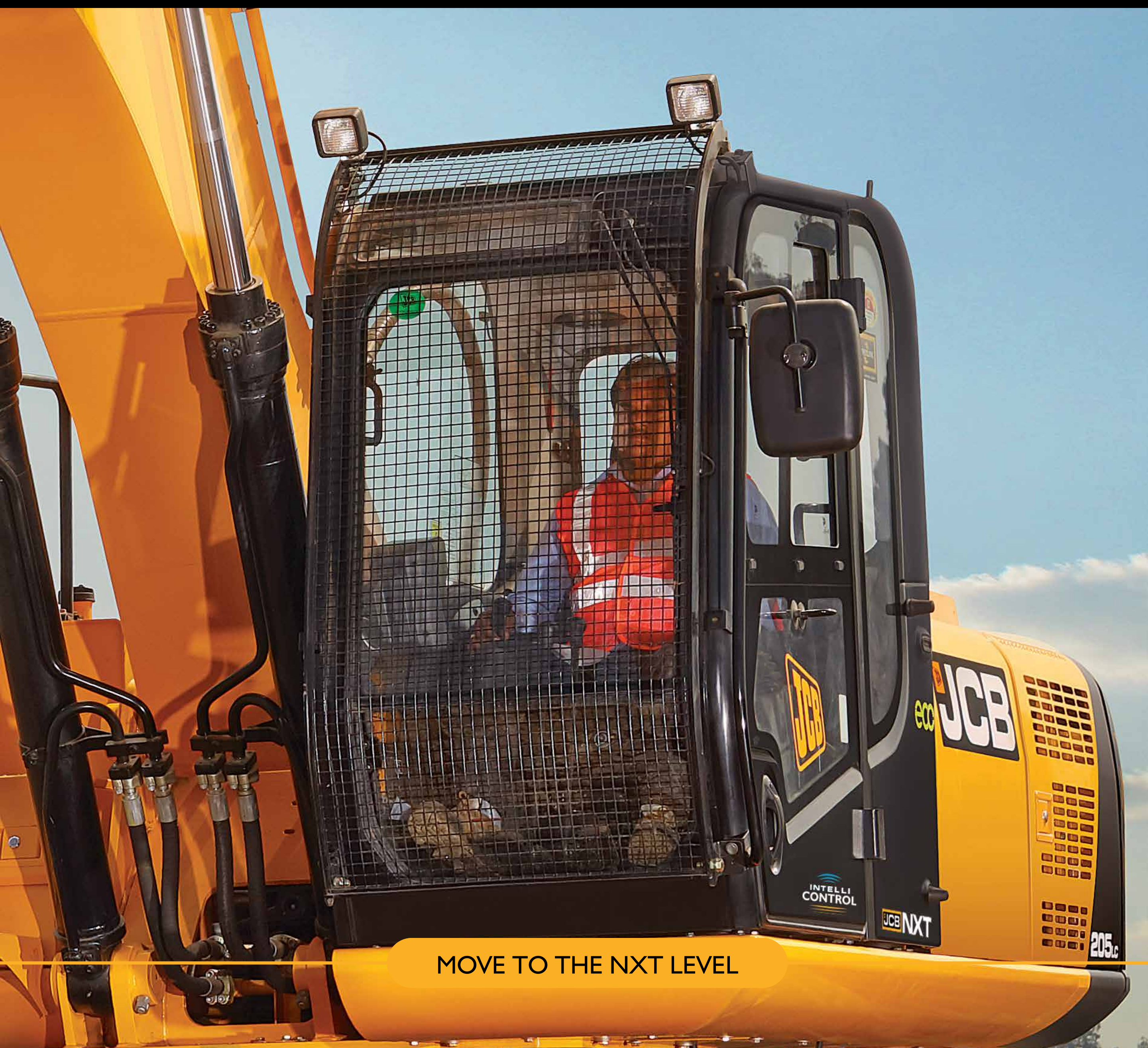

MOVE TO THE NXT LEVEL

NXT LEVEL OF SITE SAFETY



2 separate inputs required to start hydraulic operation



Engine start interlock is provided to ensure safe start of the machine.

Swing lock system enables the operator to lock the swing operations.



Hydraulic accumulator enables lowering front end without starting the engine.

MOVE TO THE NXT LEVEL



**Rock-breaker
usage guidance
to operator**

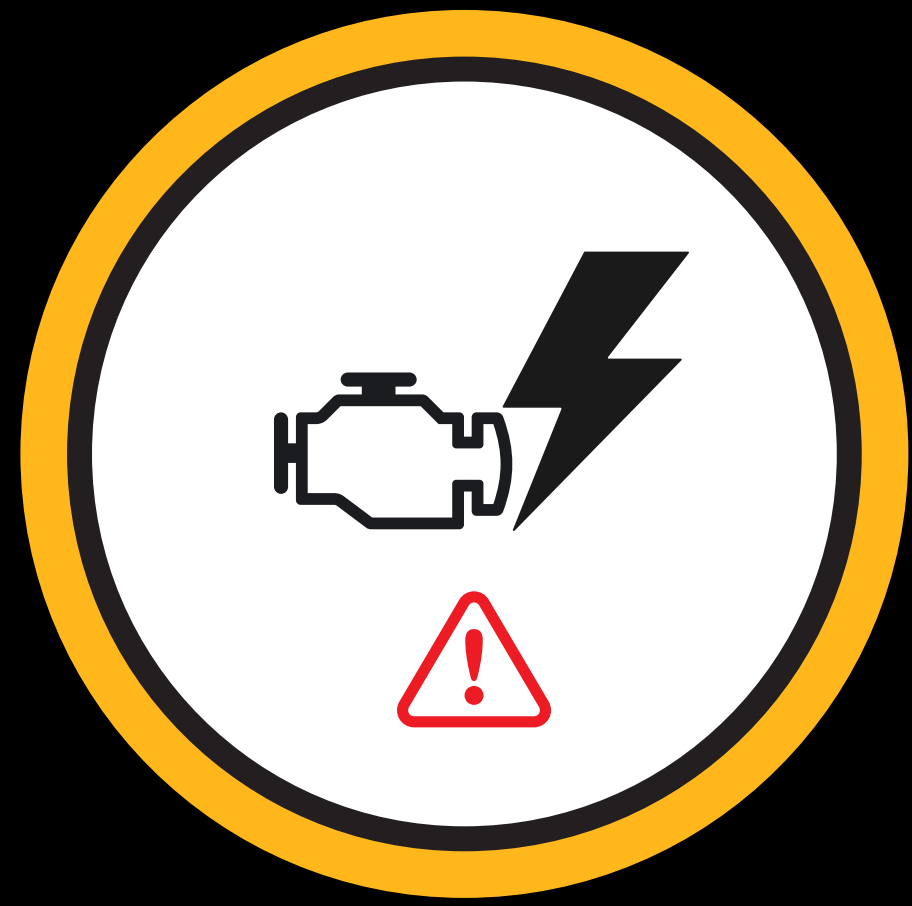

**Anti engine
restart alerts**



LOW FUEL

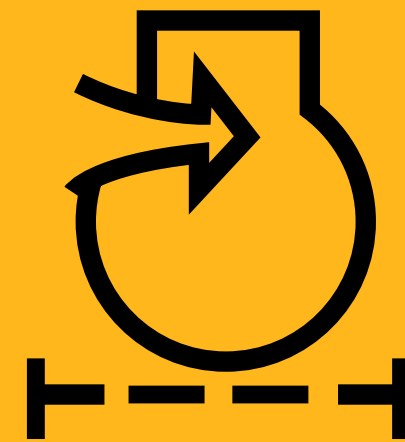

**AIR FILTER
BLOCK**

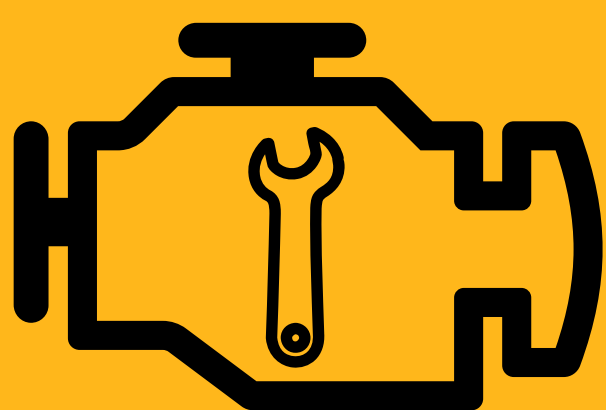

SERVICE

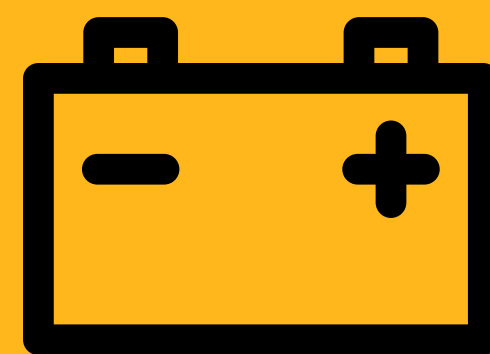

**BATTERY
LOW**

MOVE TO THE NXT LEVEL

NXT LEVEL OF CONNECT

The JCB NXT series comes with an advanced telematics system - JCB LiveLink, which is CAN based technology that keeps you connected for total control.



MOVE TO THE NXT LEVEL

1st in segment monitoring

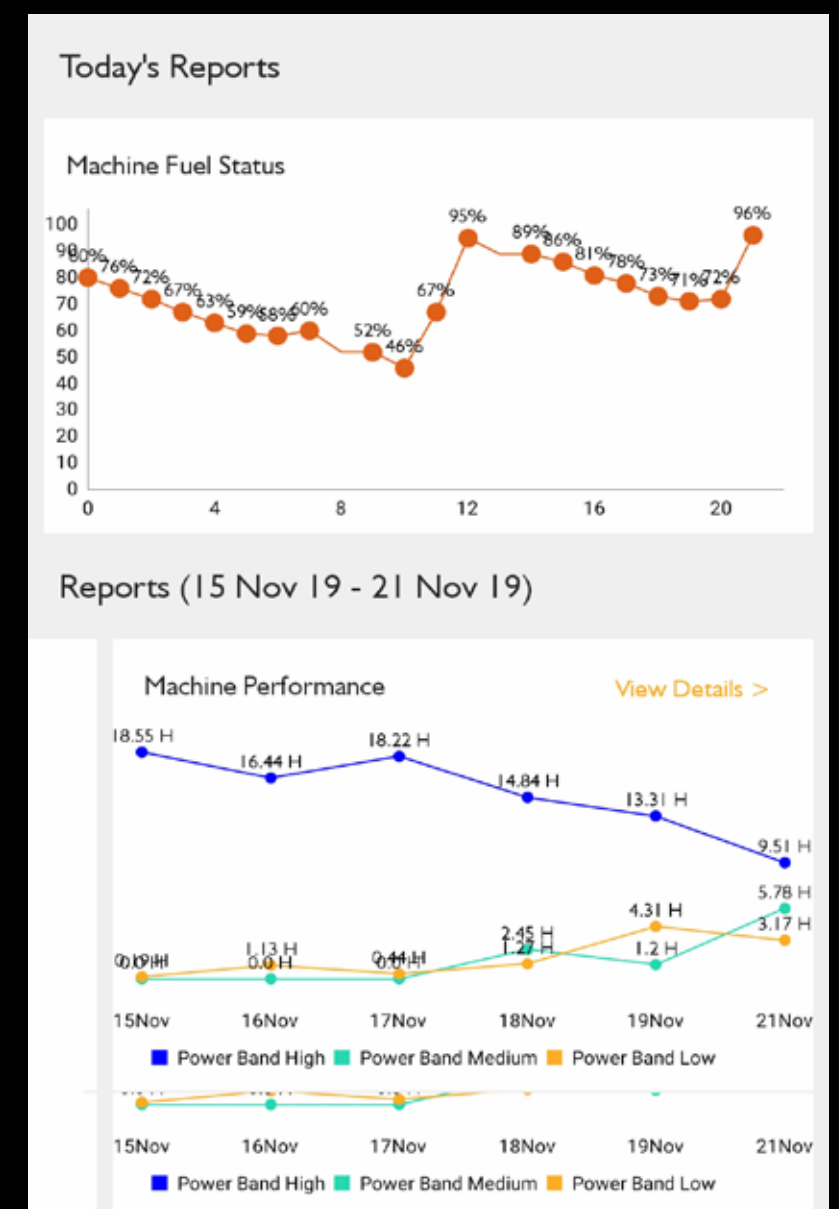
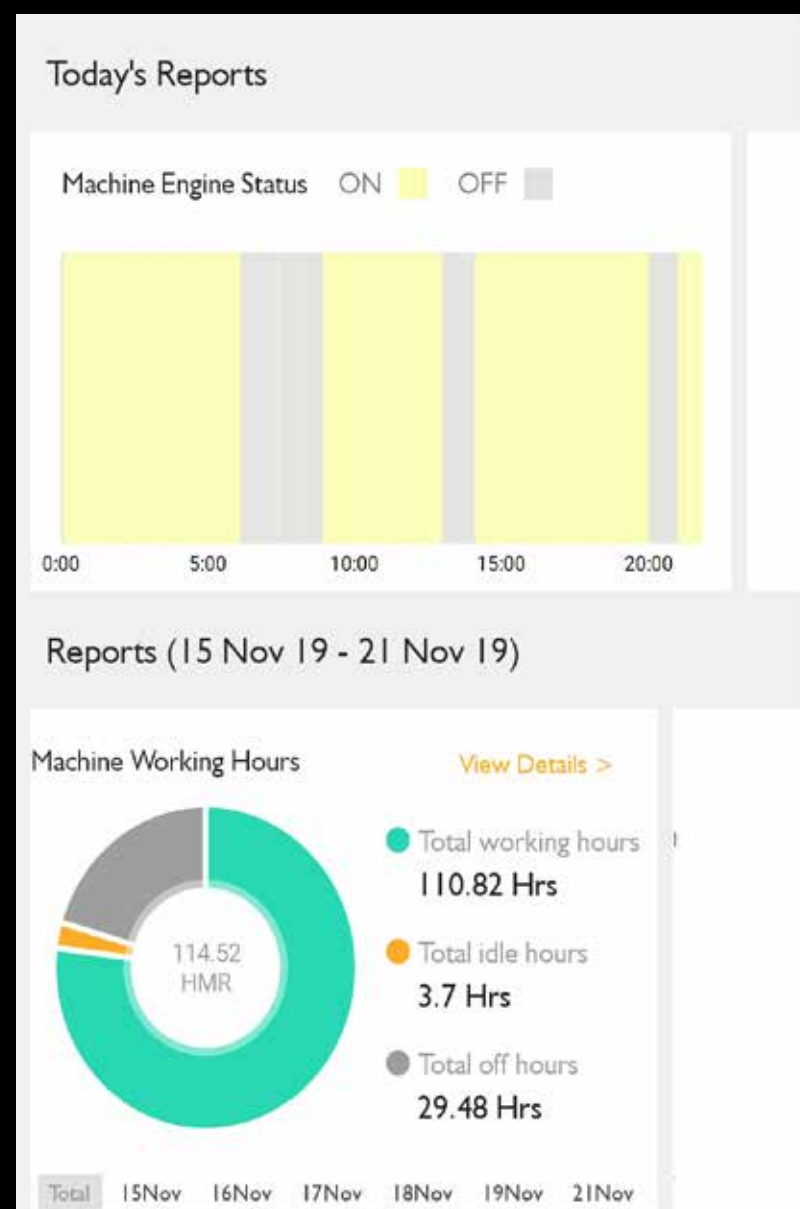
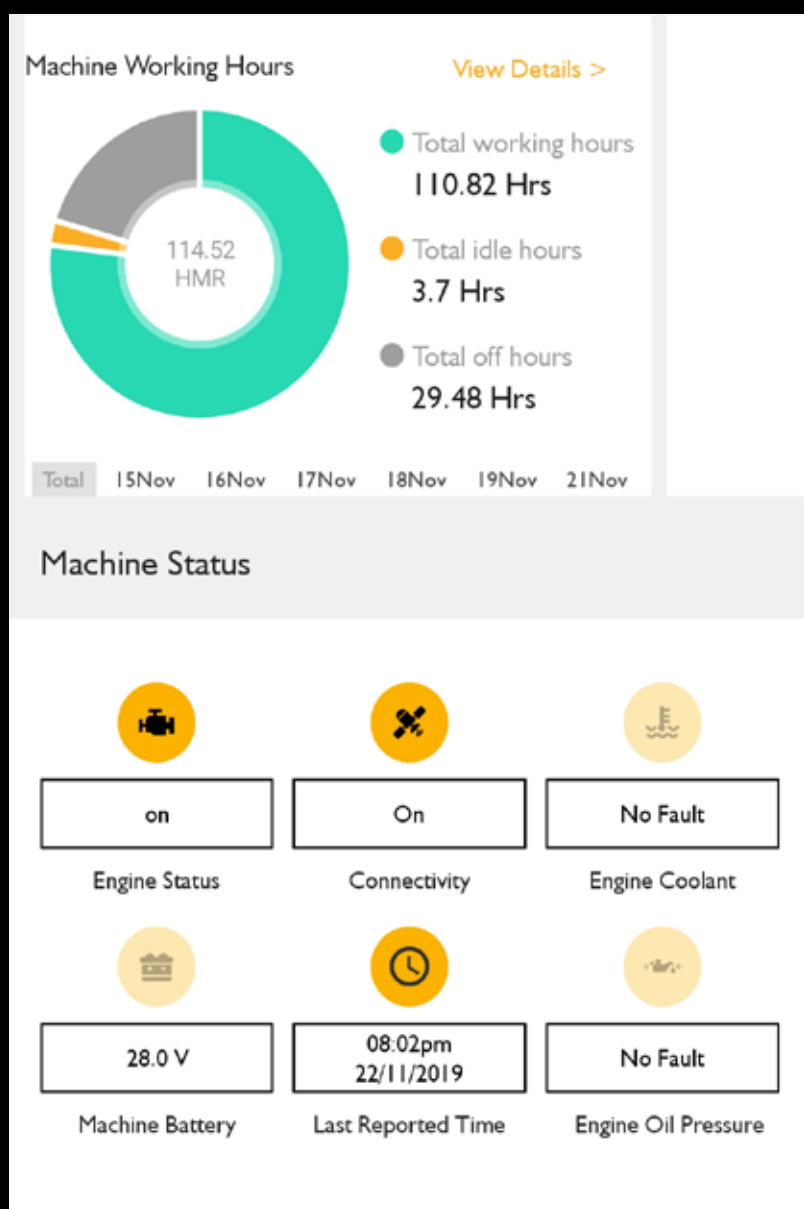

Fuel drop alerts via SMS/email



Engine high rpm shutdown report



Long engine idling report



Breaker over usages report



Breaker hour report

Download the App from

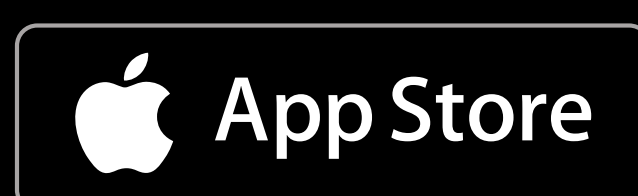

MOVE TO THE NXT LEVEL

NXT LEVEL OF CARE

GIVE YOUR MACHINE
EXTENDED WARRANTY AND CARE.



Extended Warranty Programme





Your ultimate peace of mind

JCB Careplus is an extended warranty programme that comes into effect after the machine's standard warranty expires. JCB Careplus can be purchased within the 1st year from the sale of the machine. The programme offers you peace of mind and saves your maintenance cost even after your machine's standard warranty expires.

BENEFITS OF JCB CAREPLUS



No limits on number of claims

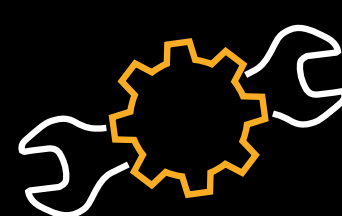

Preventive maintenance service*



Nationwide coverage*



JCB skilled manpower support



Maximum productivity



Better resale value

*Varies on JCB Careplus package selected.

JCB **NXT**

THE NXT SERIES OF EXCAVATORS

Available Range: 14 to 21.5 Tonnes



MOVE TO THE NXT LEVEL

JCB **NXT 140**
TRACKED EXCAVATOR



Engine Power:
100 hp (75 kW)

Bucket Capacity:
0.63 cu.m - 0.72 cu.m

Operating Weight:
14,320 Kg.



JCB **NXT 205_{LC}**
TRACKED EXCAVATOR



Engine Power:
140 hp (104 kW)

Bucket Capacity:
0.9 cu.m (GP/HD)

Operating Weight:
20,500 Kg (SC) / 21,250 Kg (LC)



JCB **NXT 205_{LR}**
TRACKED EXCAVATOR



Engine Power:
140 hp (104 kW)

Bucket Capacity:
0.5 cu.m GP

Operating Weight:
23,500 kg



JCB **NXT215_{LC}**
TRACKED EXCAVATOR



Engine Power:
140 hp (104 kW)

Bucket Capacity:
0.9 - 1.20 cu.m

Operating Weight:
21,500 Kg





Smart & Digital support

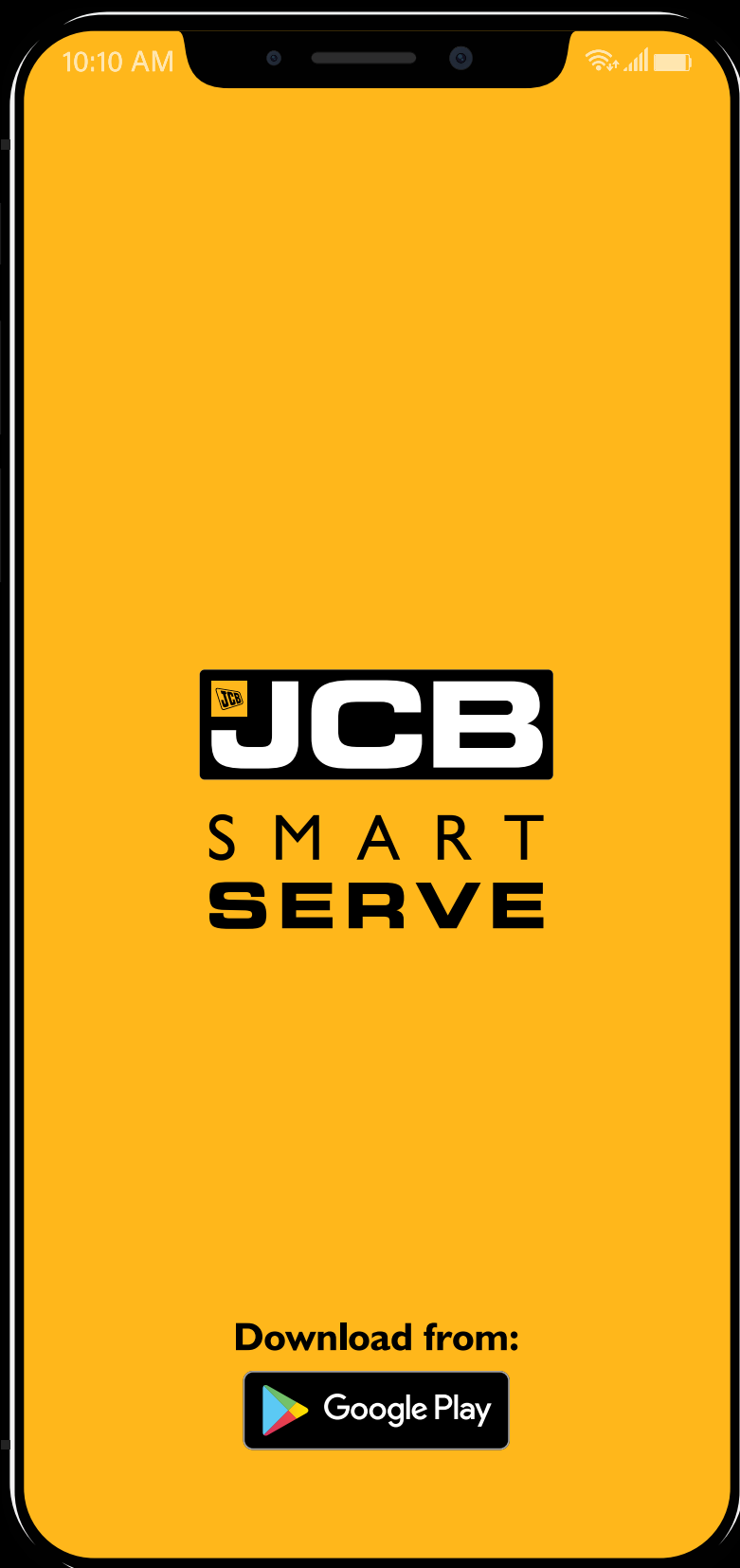

Smart Serve

Our service engineers are equipped with smart serve technology which enables us to send the closest engineer to the machine, ensuring maximum uptime.

Assured parts supply

JCB India has built a robust logistics and supply management chain across the country that facilitates the provision of parts for all machines in the shortest time. Customers can now get JCB genuine parts easily and conveniently through its mobile app.

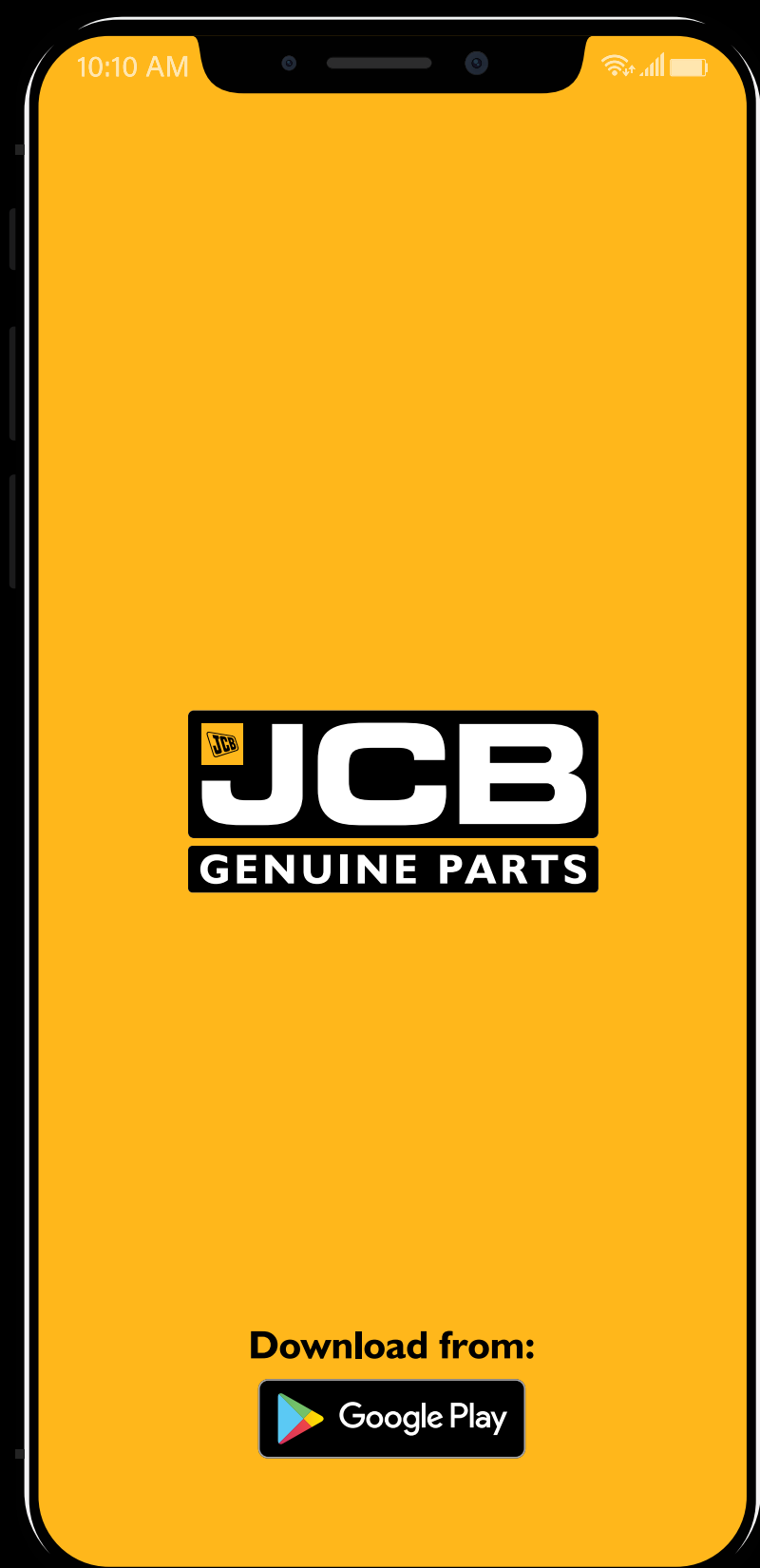

JCB EXCEEDING EXPECTATIONS
EVERYWHERE

ONE OF INDUSTRY'S FINEST
CUSTOMER SUPPORT NETWORK



WE ARE CLOSER TO YOU



65+
JCB dealers



3,000+
Mobile service
engineers

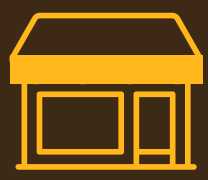

700+
Pan India outlets



4
Training centres



5,000+
Trained service
engineers



250+
Service vans



5
Parts warehouses

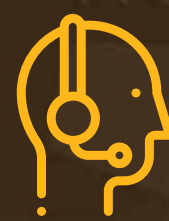

24x7
Support
12 Regional languages



**Always looking
for a better way**

**To take your business to
THE NXT LEVEL,**

Call: 1800 1037 386 | Visit: www.jcb.com

Follow us:      /JCBIndiaLtd