



# 270T & 300T 3.2

## QUICK REFERENCE GUIDE

This Quick Reference Guide DOES NOT replace the Operators Manual. You MUST read ALL the disclaimers and safety and other instructions in the Operators Manual before initially operating this product. Accordingly, no legal claims can be entertained based on the data, illustrations or descriptions in this Quick Reference Guide.

### Static Dimensions

Lift path		Vertical	Vertical
Machine model		270T	300T
A Overall length	ft-in (m)	12-6 (3.8)	12-6 (3.8)
B Wheelbase	ft-in (m)	6-11 (2.1)	6-11 (2.1)
C Angle of departure	degrees	29	29
D Overall height	ft-in (m)	6-10 (2.08)	6-10 (2.08)
E Dump height	ft-in (m)	7-5 (2.28)	7-5 (2.28)
F Loadover height	ft-in (m)	9-5 (2.88)	9-5 (2.88)
G Pin height	ft-in (m)	10-5 (3.18)	10-5 (3.18)
H Reach @ ground level	ft-in (m)	3-7 (1.1)	3-7 (1.1)
I Max. reach @ full height	ft-in (m)	4-3 (1.30)	4-3 (1.30)
J Reach @ full height - fully dumped	ft-in (m)	2-11 (0.9)	2-11 (0.9)
K Dig depth clearance	in (mm)	-3/8 (-10)	-3/8 (-10)
L Rollback @ ground	degrees	30	30
M Dump angle	degrees	42	42
N Width over tires - standard	ft-in (m)	6-3 (1.9)	6-3 (1.9)
O Bucket width - standard	ft-in (m)	6-3 (1.9)	6-3 (1.9)
Bucket capacity - standard	yd <sup>3</sup> (m <sup>3</sup> )	0.56 (0.43)	0.56 (0.43)
Turning radius			
Bucket corner radius	ft-in (m)	7-7 (2.3)	7-7 (2.3)
Quick hitch radius	ft-in (m)	5-7 (1.7)	5-7 (1.7)
Rear chassis radius	ft-in (m)	5-9 (1.76)	5-9 (1.76)
P Ground clearance	in (mm)	0-9 (230)	0-9 (230)

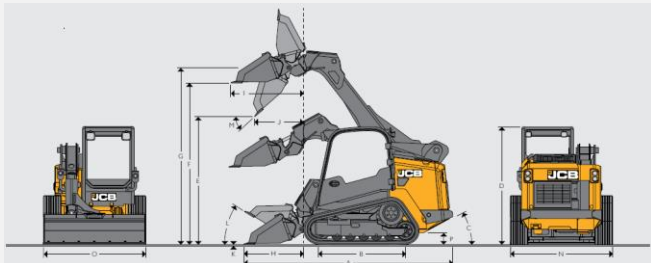

### Tie Down Points

**\*\*Tie Down Points are same on Wheel & Track models\*\***

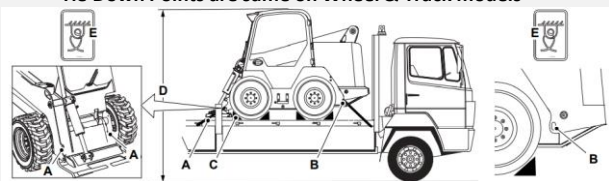

- A. Front tie down point
- B. Rear tie down points
- C. Blocks
- D. Machine height
- E. Tie down point label

### Cab and Switch Panel

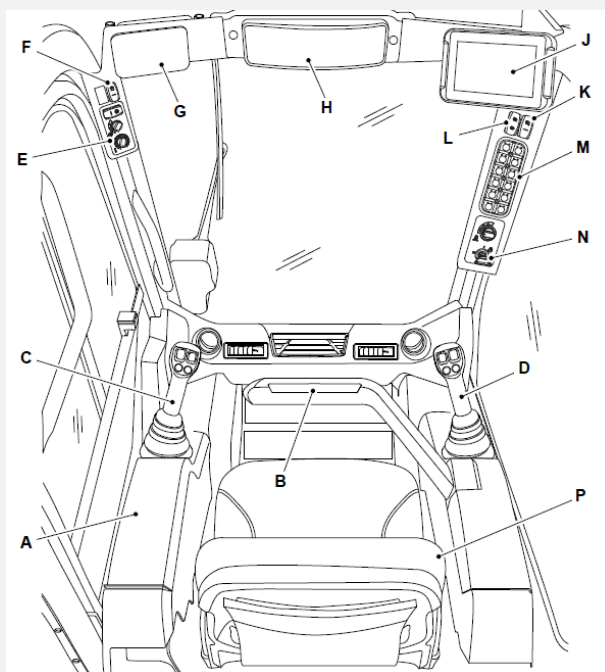

- A Left armrest (contains 12V accessory socket)
- B Right interlock bar
- C Left joystick control lever
- D Right joystick control Lever
- E Cab HVAC (Heating Ventilation Air Conditioning)
- F Beacon
- G Radio
- H Interior mirror
- J Colour display
- K Auto stop
- L Exhaust regeneration inhibit
- M Console switches
- N Ignition switch
- P Operator seat

### Driving Controls – ISO Pattern

- A. Left Joystick Control Level
- B. Forward Drive
- C. Backward Drive
- D. Forward Left Drive
- E. Forward Right Drive
- F. Backward Left Drive
- G. Backward Right Drive
- H. Spin turn left
- J. Spin turn right

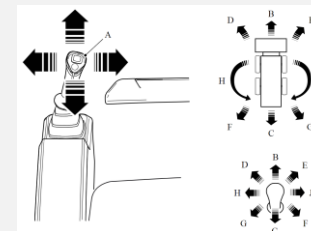

### Driving Controls – H Pattern

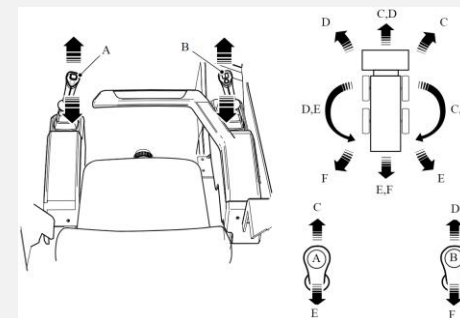

- A. Left Joystick Control Lever
- B. Right Joystick Control Lever
- CD. Forward drive
- C. Forward Right drive
- D. Forward left drive
- DE. Spin turn left
- CF. Spin turn right
- F. Backwards left drive
- E. Backwards right drive
- EF. Backwards drive

### Start Up Sequence

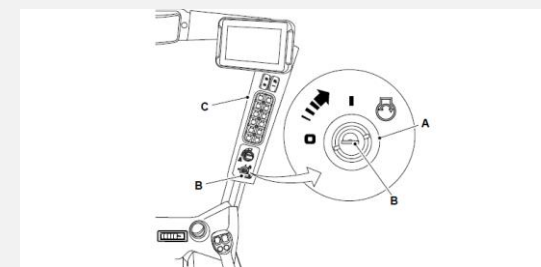

1. Buckle seatbelt
2. Lower left arm
3. Lower interlock bar
4. Insert key and turn to position "I"
5. Disengage parking brake



## Instrument Panel

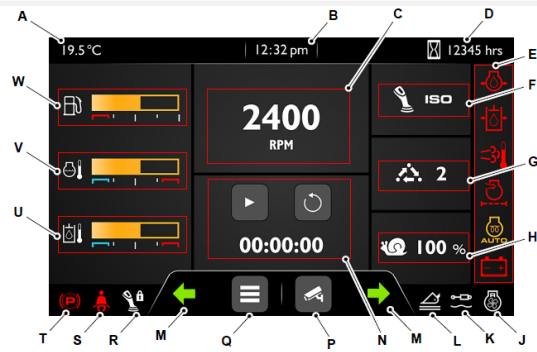

- |                             |                               |
|-----------------------------|-------------------------------|
| A. Outside temperature      | N. Timer                      |
| B. Time                     | P. Camera                     |
| C. Engine speed             | Q. Main menu                  |
| D. Hour meter               | R. Joystick isolate           |
| E. Dynamic telltale         | S. Seatbelt status            |
| F. Joystick ISO/H selection | T. Park brake                 |
| G. Mode select              | U. Hydraulic oil temperature  |
| H. Creep (snail)            | V. Engine coolant temperature |
| J. Reverse fan              | W. W Fuel level indicator     |
| K. Aux unlock               |                               |
| L. Parallel lift            |                               |
| M. Direction indicators     |                               |

## Switch Panel

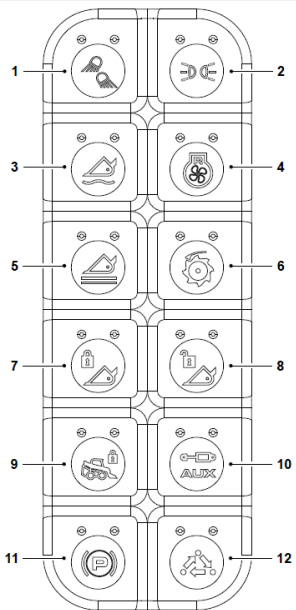

1. Front/Rear Work Lights
2. Side Lights
3. SRS (Smooth Ride System)
4. Reverse Fan (Option)
5. Parallel Lift
6. High Flow (Option)
7. Lock Quickhitch Bucket
8. Unlock Quickhitch Bucket
9. Loader Lock
10. Aux Unlock
11. Park Break
12. Mode Select

## Lift Arm Controls

### ISO Pattern

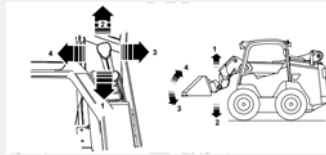

1. Lift arm raise
2. Lift arm lower
3. Shovel dump
4. Shovel crowd

### H-Pattern (option)

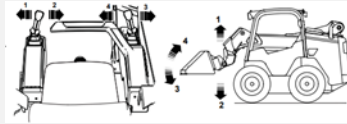

1. Lift arm raise
2. Lift arm lower
3. Shovel dump
4. Shovel crowd

## Controls – Left Joystick

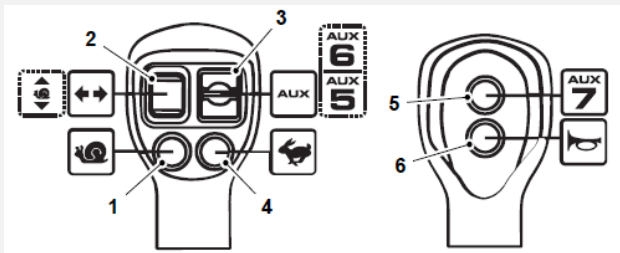

1. | Creep speed drive control (option)
2. Turn signal (option)/Creep setting (option)
3. Auxiliary proportional control switch functions : 5 and 6
4. 4 Two speed drive control (option)
5. Auxiliary control switch function : 7
6. Horn

## Controls – Right Joystick

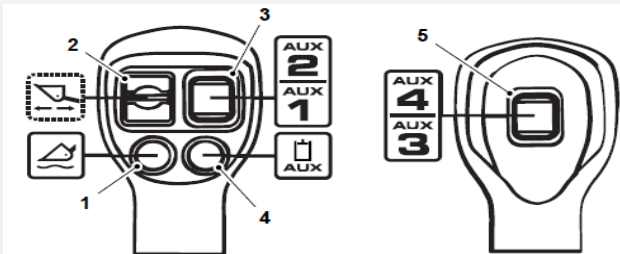

1. | Float switch (option)
2. Extend retract proportional control switch (TS ONLY)
3. Attachment first functions : 1 and 2 switch
4. Auxiliary proportional control hold switch
5. Attachment second functions : 3 and 4 switch

## Auxiliary Circuit Controls

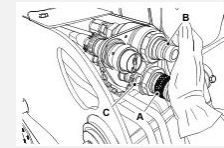

- A. Auxiliary coupler
- B. Auxiliary coupler
- C. Auxiliary drain coupler

## Service Points

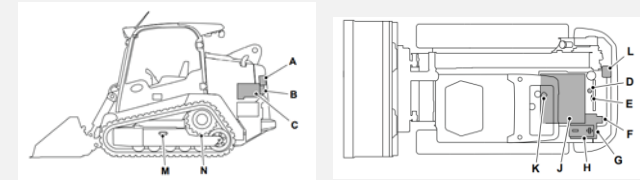

- A. Coolant expansion bottle
- B. Fuel sedimenter
- C. Air intake
- D. Engine oil filler cap
- E. Engine oil dipstick
- F. Hydraulic oil level indicator, Hydraulic oil filler cap
- G. Battery isolator
- H. Battery
- J. Radiator
- K. Radiator cap
- L. Window washer fluid bottle
- M. Track tensioner
- N. Sprocket

## Access Covers

### Engine Compartment Cover

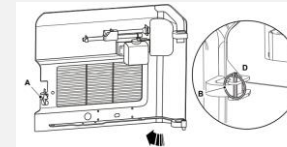

- A. Handle
- B. Locking pin
- C. Locking position

- B. Locking pin
- C. Stowage position

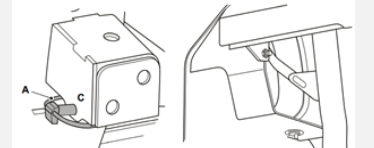

### Rear Cover

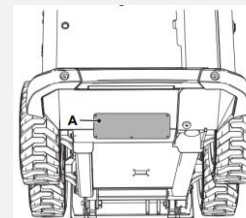

- A. Rear Cover