



507-42, 509-42, 510-42,  
510-56, 512-56, 514-56

## QUICK REFERENCE GUIDE

This Quick Reference Guide DOES NOT replace the Operators Manual. You MUST read ALL the disclaimers and safety and other instructions in the Operators Manual before initially operating this product. Accordingly, no legal claims can be entertained based on the data, illustrations or descriptions in this Quick Reference Guide.

### BEST PRACTICES

1. Carry a load as low as possible while maintaining good visibility.
2. Forks should be tilted back when in transport – with or without a load, cradle the load.
3. Fork tips should be on the ground when unit is parked.
4. Rather than driving into the load, extend the boom to easier see the forks in the load.

### Static Dimensions

Machine model	506-36	507-42	509-42	510-42	510-56	512-56	514-56
A Overall height	ft-in 8-3				ft-in 8-10		ft-in 8-11
B Overall width over tyres	ft-in 7-10				ft-in 8-1		
C Inside width of cab	ft-in 3-1						
D Front track	ft-in 6-4		ft-in 6-7				
E Wheelbase	ft-in 10-4						
F Overall length to front tyres	ft-in 17-1	ft-in 17-8	ft-in 17	ft-in 17-8	ft-in 17-9	ft-in 18-4	
G Overall length to front of carriage	ft-in 19-5	ft-in 21-3	ft-in 20-7	ft-in 21-3	ft-in 21-7	ft-in 22-4	
H Ground clearance	ft-in 1-3.5				ft-in 1-5.5		
Weight	lbs 20,270	lbs 21,300	lbs 22,430	lbs 23,858	lbs 29,900	lbs 30,635	lbs 32,143

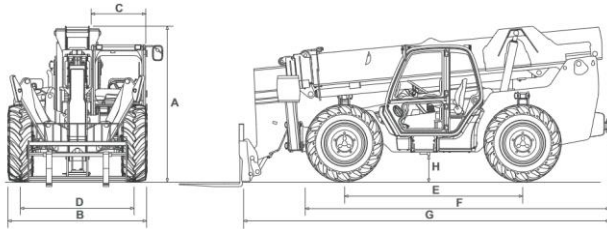

### Tie Down Points

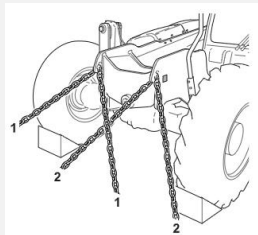

Front Anchor Points

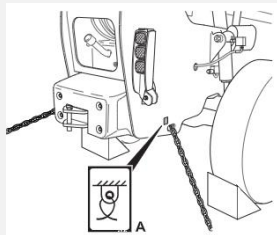

Rear Anchor Points

### Cab Layout

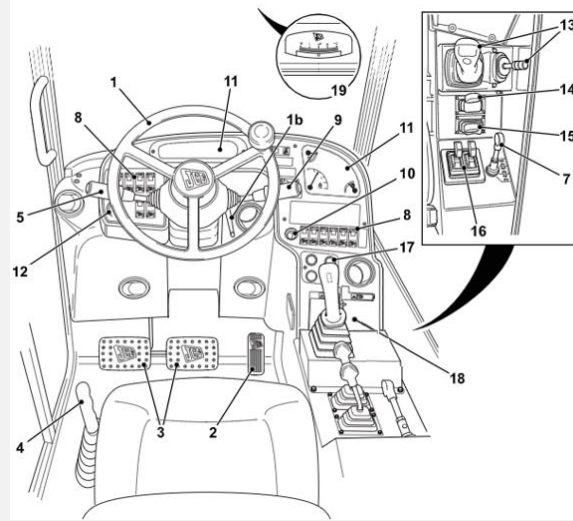

1. Steering Wheel
2. Accelerator Pedal
3. Foot Brake Pedal
4. Park Brake Lever
5. Transmission Lever (4-Speed Transmission)
7. Steer Mode Selector
8. Console Switches
9. Multi-Purpose Steering Column Switch (4-Speed Transmission)
10. Starter Switch
11. Instrument Panel
12. Hourmeter
13. Boom and Carriage Controls
14. Auxiliary Controls
15. Chassis Leveling (Sway) Controls
16. Stabilizer Controls (if fitted)
17. Air Conditioning and Cab Heater Controls
18. Load Charts
19. Inclinometer

### Instrument Panel

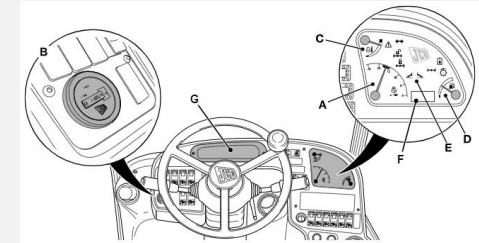

- |                              |                    |
|------------------------------|--------------------|
| A. Tachometer                | E. Warning Lights  |
| B. Hourmeter                 | F. Digital Display |
| C. Coolant Temperature Gauge | G. Warning Lights  |
| D. Fuel Level Gauge          |                    |

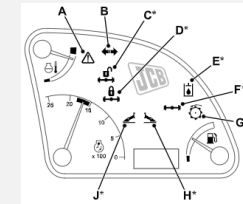

- A. Malfunction Indicator Lamp (MIL)
- B. Not used
- C. RAS System – Cushioned Mode Indicator
- D. RAS System – Locked Mode Indicator
- E. Hydraulic Isolation – Fault Indicator
- F. RAS System – Fault Indicator
- G. Not used
- H. Right-Hand Stabilizer Indicator
- I. Left-Hand Stabilizer Indicator

### Start Up Sequence

<p><b>1. Insert Isolator Key (A)</b></p> <p>Insert battery isolator key switch, push and turn 90° (degrees symbol)</p>	<p><b>2. Disarm the immobiliser</b></p> <p>If installed, clear with MID then key in the code followed by enter.</p>	<p><b>3. Set to Neutral</b></p> <p>Put the forward / reverse lever into neutral.</p>
<p><b>4. Insert Key</b></p> <p>Insert key into ignition switch (A)</p>	<p><b>5. Start Machine</b></p> <p>Turn the ignition key to the start position (position II) and hold it there until the engine starts.</p>	<p><b>6. Operate Hydraulics</b></p> <p>Operate the hydraulic services to make sure that each function is working correctly and to help warm up the hydraulic system.</p>

Access additional information

[www.servicepro.jcb.com](http://www.servicepro.jcb.com)



## Single Lever Control

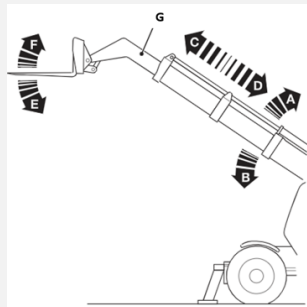
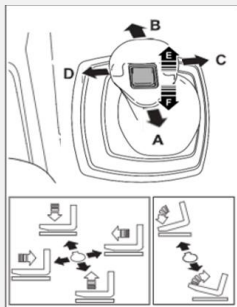

- A. Boom Raise
- B. Boom Lower
- C. Boom Extend
- D. Boom Retract

- E. Carriage Tilt Forward
- F. Carriage Tilt Back
- G. Inner Boom

## Auxiliary Control

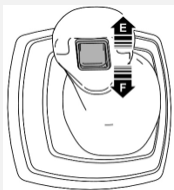

Roll the thumb switch (E) forward or (F) backwards to use desired function

## Stabilizer Controls

1. Park the machine on firm ground.
2. Turn off the stabilizer isolation switch (D).
3. Push the control levers (B) forward to lower the stabilizer legs (F).
4. Pull the control levers (C) back to raise the stabilizer legs (E).
5. Before you operate the boom, make sure the machine is level and stabilizer controls are isolated.

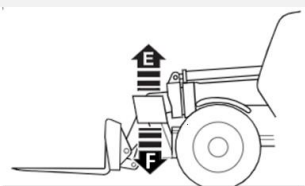

- A. Stabilizer control levers
- B. Stabilizer legs- lower
- C. Stabilizer legs – raise
- D. Stabilizer isolation switch

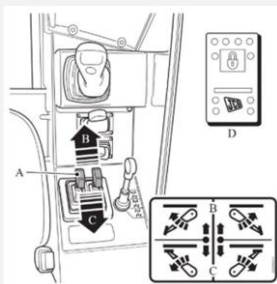

## Chassis Levelling (Sway) Operation

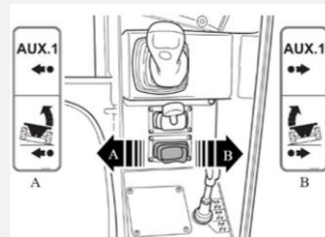

To operate move the lever to either the right or left until the machine shows as level on the inclinometer.

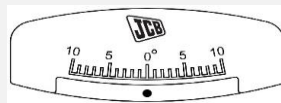

## Vehicle Steer Mode - Manual

1. Stop the machine. Set the gear lever to the neutral position
2. Turn the steering wheel until all the wheels are pointing in the straight ahead position
3. Use the lever (A) to select the steering mode:
  - B. 4 wheel steer
  - C. 2 wheel steer
  - D. Crab steer
4. Operate the steering wheel until the wheels straighten up to re-phase the mode.



## Access Covers

### Engine Compartment

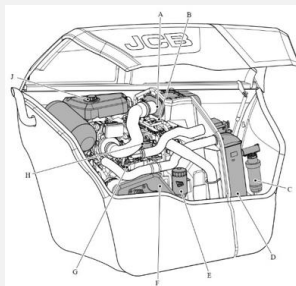

- A. Air Filter
- B. Transmission Oil Dipstick
- C. Water Separator
- D. Radiator
- E. Engine Oil Filter
- F. Drive Belt Guard
- G. Engine Oil Dipstick
- H. Engine Oil Filler Cap
- J. Coolant Expansion Tank

## Access Covers

### Battery Compartment

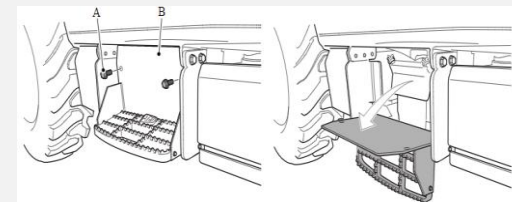

1. Make the machine safe.
2. Hold the battery cover, then remove the bolts (A)
3. Open cover (B).

### Rear Cover

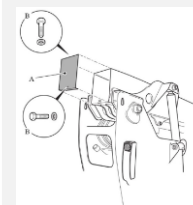

1. Make the machine safe.
2. Hold the lift arm cover (A), then remove the bolts (B)
3. Lower the cover.

## Connecting Attachments

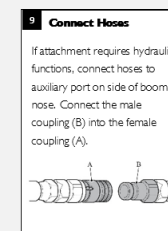
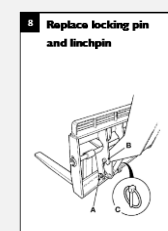
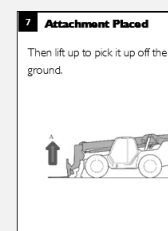
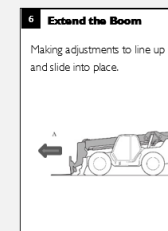
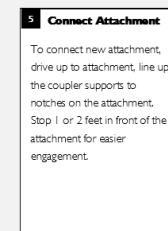
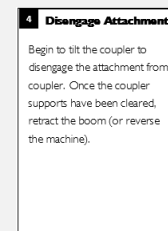
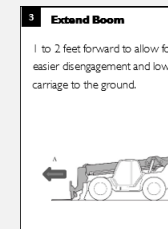
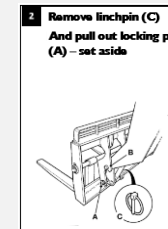
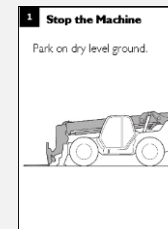

**JCB 510 42**  
NORTH AMERICA

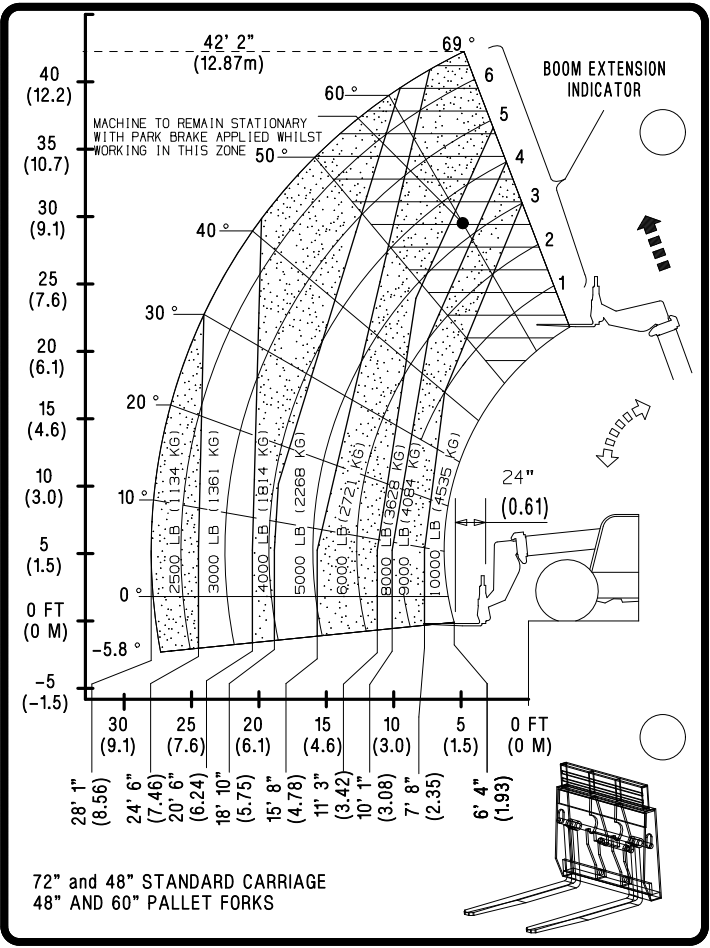

**JCB 510 42**  
NORTH AMERICA

PSI	TIRE SIZE	PR	PSI
81	14.00-24	16	81
67	17.5-25	16	65

INFLATION PRESSURES FOR PNEUMATIC TIRES ONLY.

TIRES ON THIS VEHICLE MAY CONTAIN SEALANT OR FOAM BALLAST.

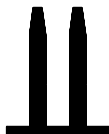

# 510 42

NORTH AMERICA

PALADIN 10000 LB & 12000 LB 60" FORK POSITIONER

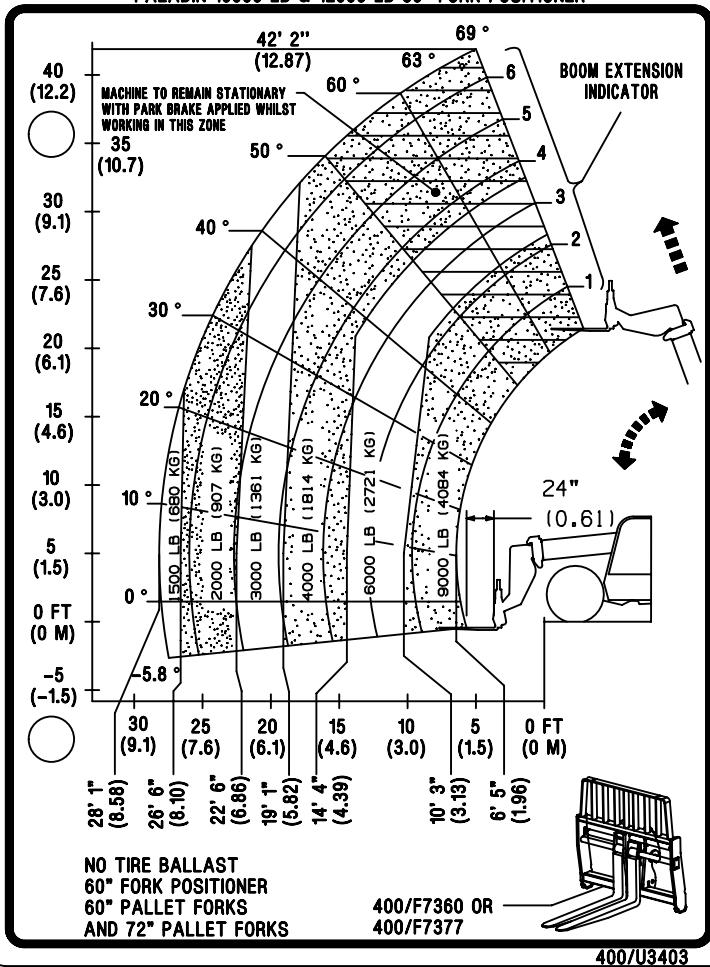

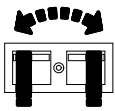

**JCB 510 42**  
NORTH AMERICA

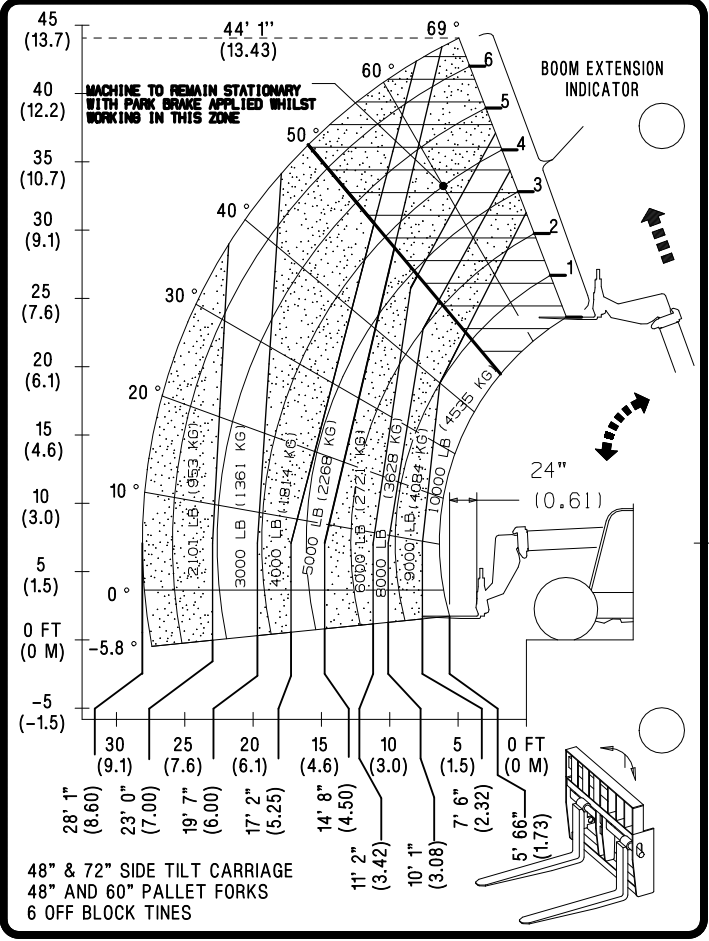

**JCB 510 42**  
NORTH AMERICA

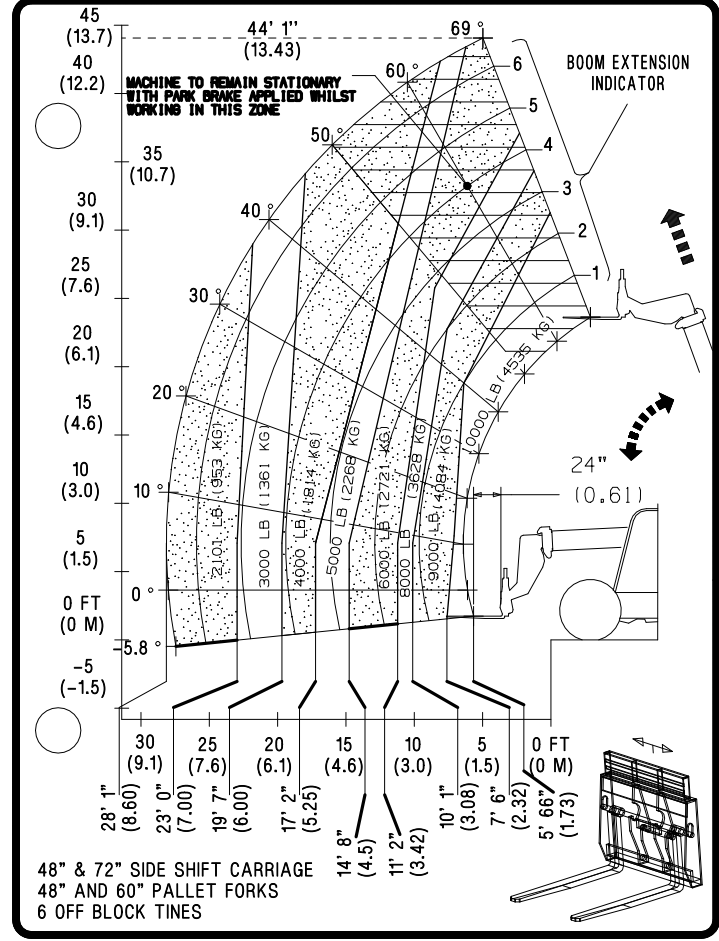

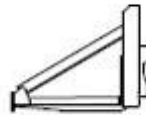

# JCB 510 42

NORTH AMERICA

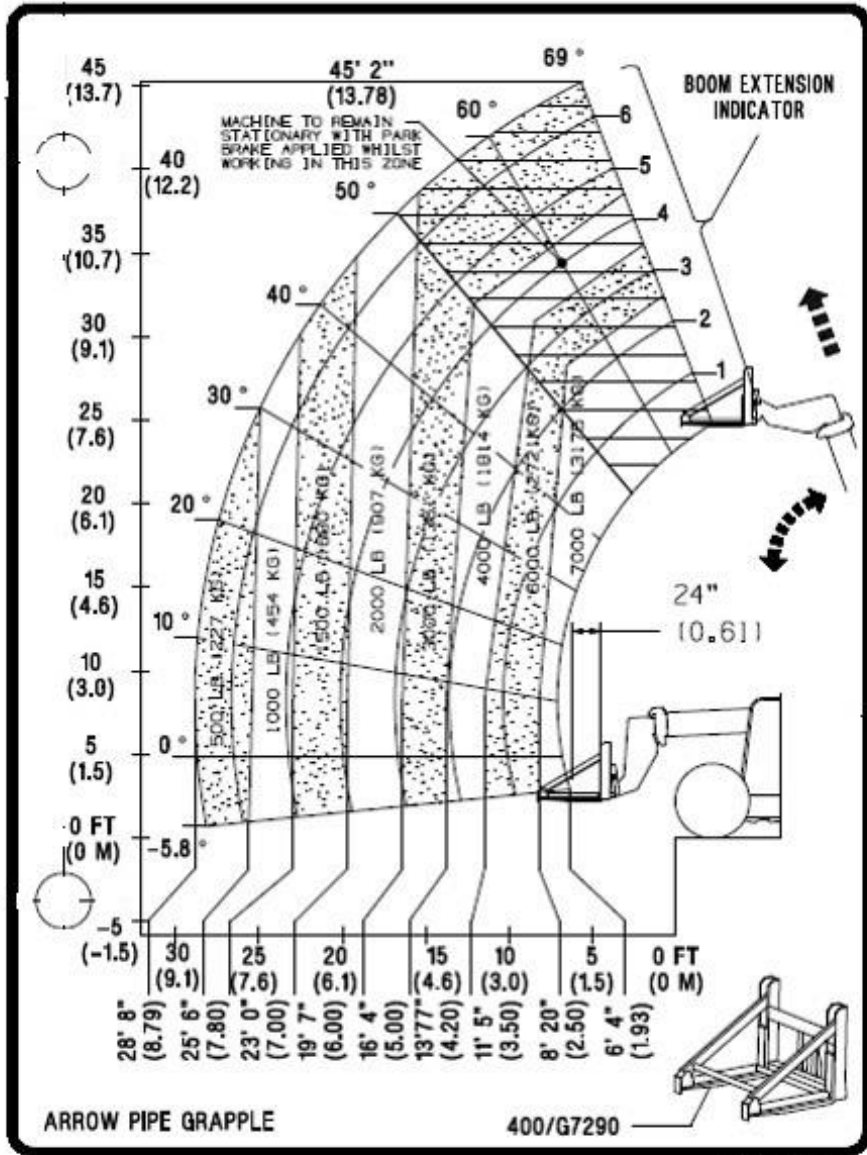

ARROW PIPE GRAPPLE

400/G7290

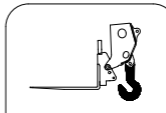
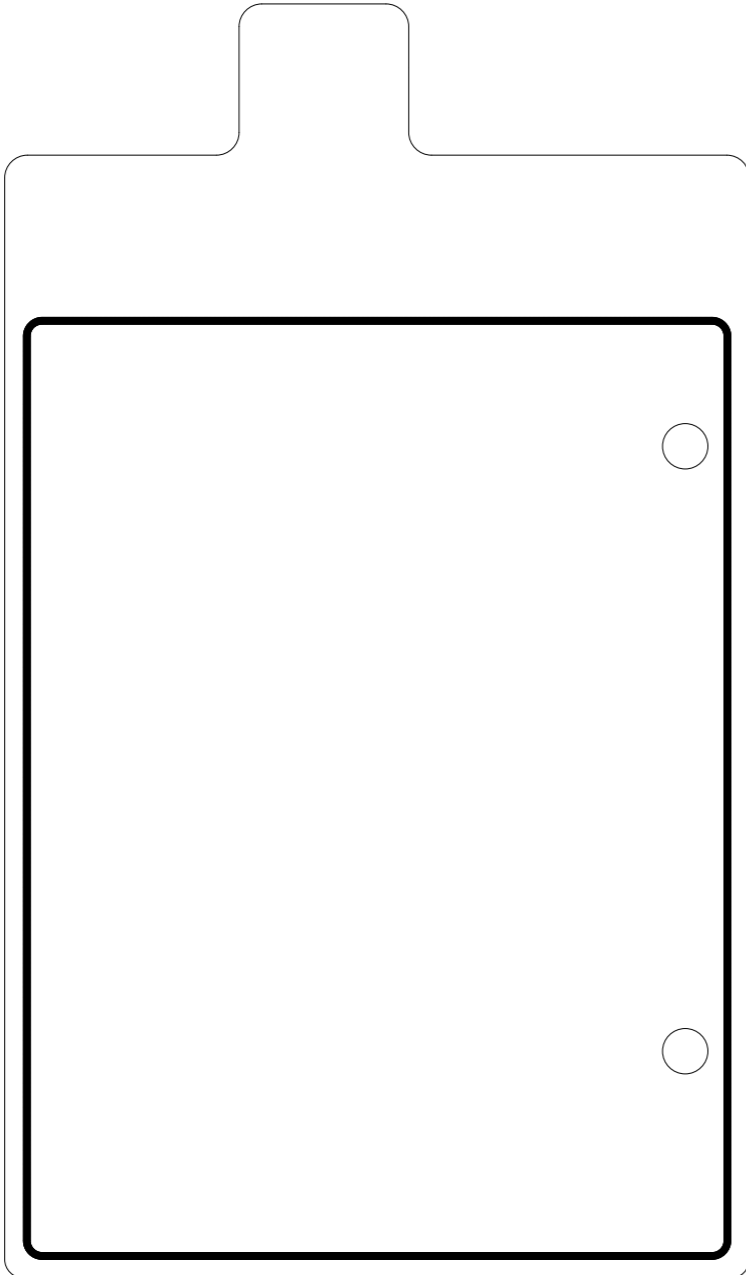

**JCB** **510 42**  
NORTH AMERICA

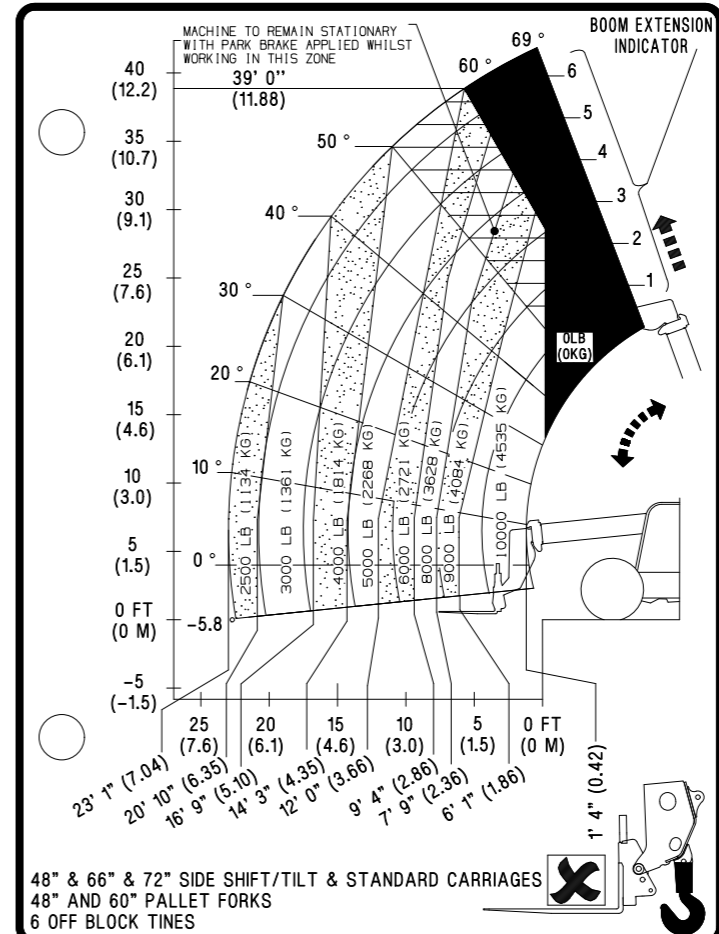

**JCB** 510 42  
® NORTH AMERICA

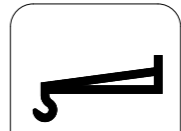
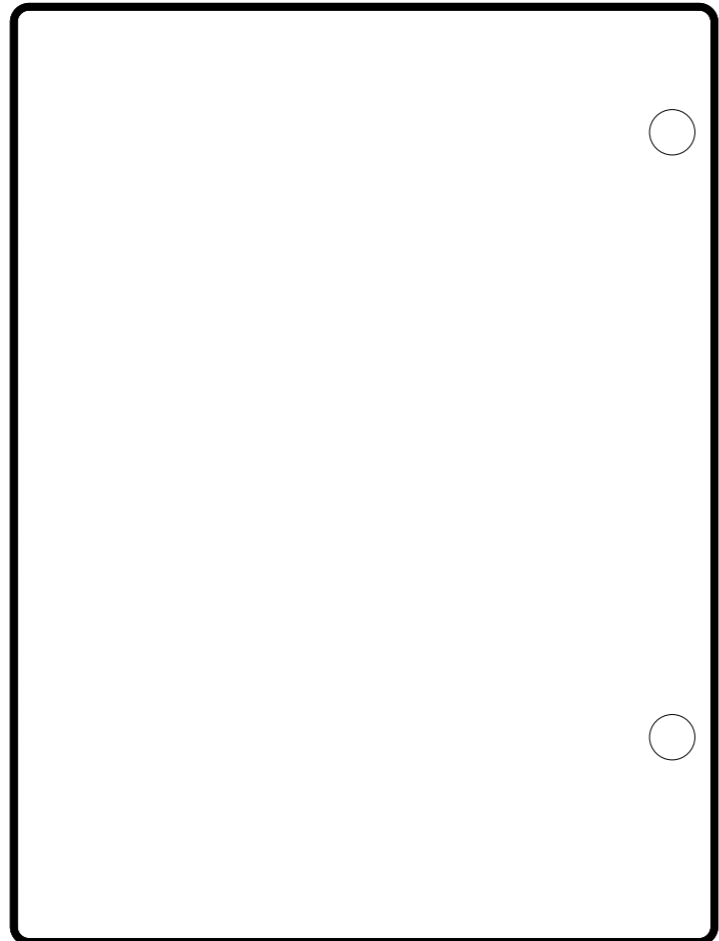

**JCB** 510 42  
® NORTH AMERICA

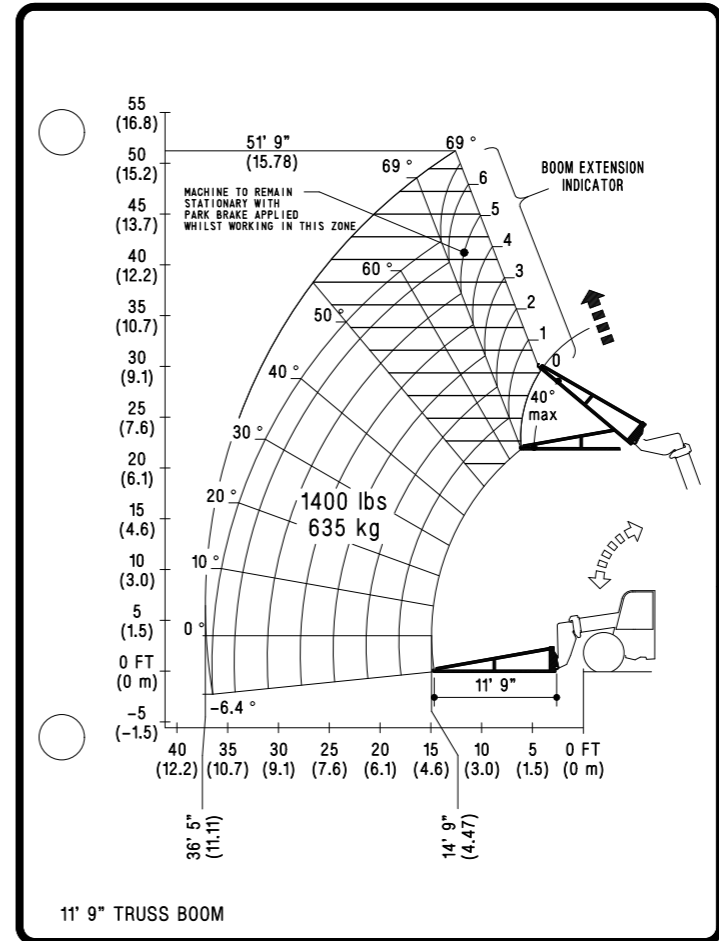



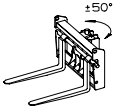

# JCB 510 42

NORTH AMERICA

BS 56.6

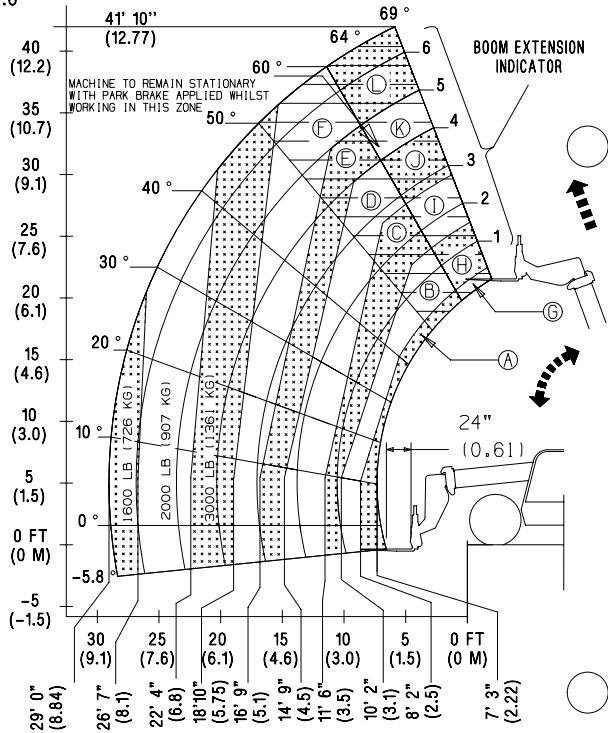

CARIAGE: 332/E5286 FORKS: 60"x5"x2" MAX

(LBS)	A	B	C	D	E	F	G	H	I	J	K	L
	10,000	9,000	8,000	6,000	5,000	4,000	10,000	9,000	8,000	6,000	5,000	4,000
	5,000	5,000	4,000	4,000	4,000	3,000						



# JCB 510 42

NORTH AMERICA